

ROYAL

Royal Precision Tools Corporation

High Precision Spindles Solutions

Total Solution • State of the Art



PRECISION

STABILITY

RIGIDITY

EFFICIENCY

HISTORY

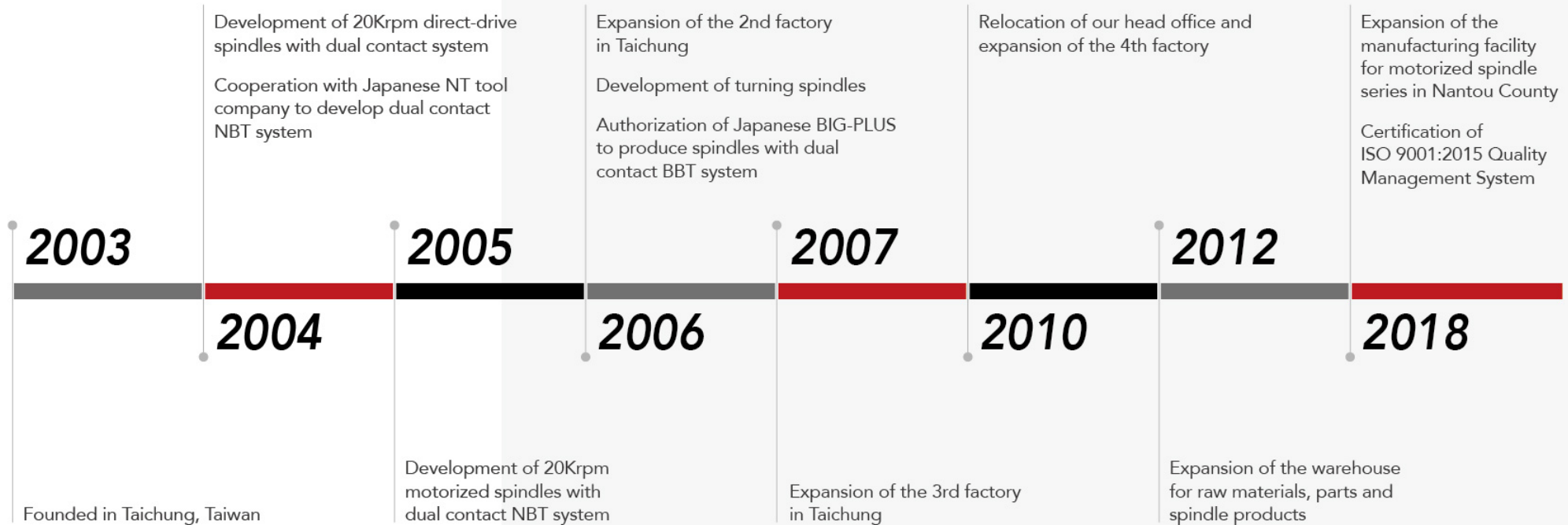

Your Spindle Solutions
Speed, Precision, Rigidity

PRECISION

STABILITY

RIGIDITY

EFFICIENCY

About ROYAL

Precision Spindle Brand 100% Made in Taiwan

Royal Precision Tools Corporation has specialized in high precision machine tool spindles since 2003 in Taichung, Taiwan. Our comprehensive product range of spindles is well deployed in various machine types as milling, turning, mill-turn, multi-spindle, tapping and grinding.

With professional competencies of R&D, designing, manufacturing, assembling and repairing, ROYAL has won outstanding recognition in the machine tools industry along the way.

Quality Assurance State of the Art

Every single spindle is examined with uncompromising standards and every new spindle is designed to increase spindle performance and go beyond common expectations. We have indeed made great efforts to ensure consistent high-quality spindles for our customers to rely on.

Customer-Oriented Added Value

Royal, a customer-oriented company, is always projecting the most fit-in services and total solutions with customized design spindles and top expertise in the field. All details and segments have to be oriented towards customers' benefits.

We believe that only by fulfilling the interests of our business partners can we work together to create the highest added value for the machine tools industry.

ROYAL

Core Competencies

**30+ years Industrial
Experience**

**μm Precision Standard
High Recognition**

**20,000+ m²
Headquarter & Factories**

**3000+ Spindles
Monthly Productivity**

**9,200+ Spindles
Custom-Designed**

**10+ years
Partnership with Japan**

**90%
Self-Made Parts Rate**

**19,000+
Self-Made Parts Kinds**

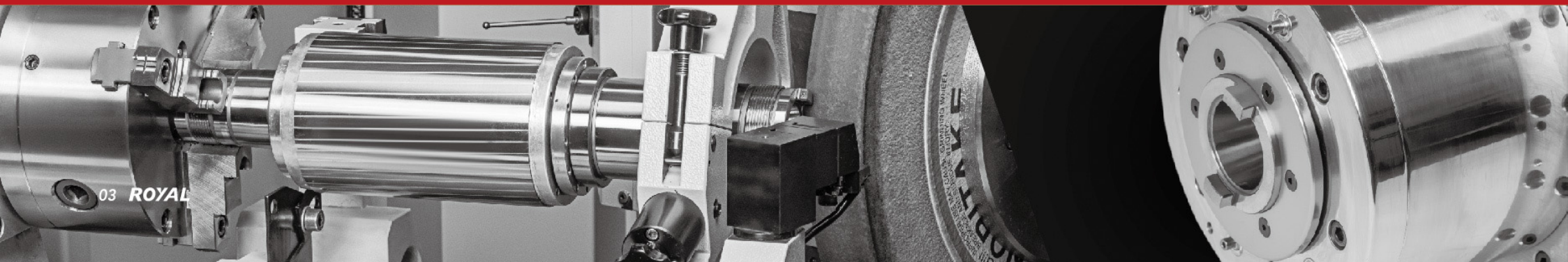

One-Stop Solution

01

Spindle
Customization

02

Integrated Production
Equipment

03

Environment
Perfection

04

Mechanism of
Spindle Assembly

05

Parts Quality
Inspection

06

Quality Assurance
Program

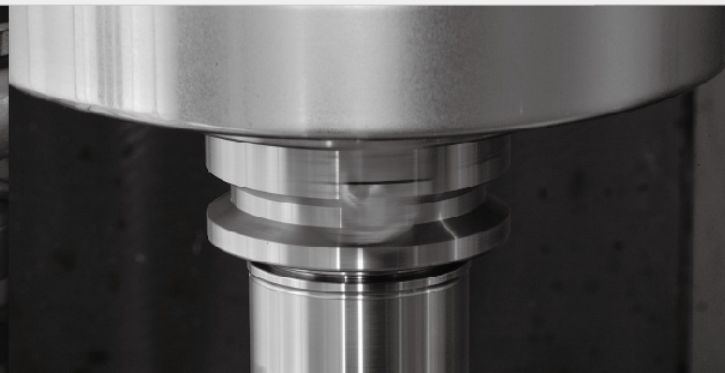

Motorized Spindle

High Precision

- ▶ High dynamic rotary accuracy
- ▶ Balancing adjustment within G1, low vibration
- ▶ Modularized easily
- ▶ Low thermal displacement, high stability
- ▶ Short overall length, low inertia

High Efficiency

- ▶ High motor power, high moments of inertia



Model	Housing OD (mm)	Max. Speed (rpm)	Taper	Clamping force (kgf)	Bearing ID (mm)	Lubrication	Motor Specification	Power S1 (kW)	Torque S1 (Nm)	Cooling	Weight (kg)	CTS
RE3012	Ø120	30000	BT30/BBT30	250±50	Ø45+Ø35	Grease	ATE AC90/100/4	7.5	6	Pure water	Approx. 30	Optional
REH135		36000	HSK E40	680~880	Ø45+Ø40	Oil-air						
RE4121	Ø150	20000	BBT40	1000±100	Ø70+Ø60	Grease	ATE AC120/120/4	15	12.1	Pure water	Approx. 82	
REH063		24000	HSK A63	1800~2300	Ø70+Ø55	Oil-air						
RE4122	Ø170	20000	BBT40	1260±60	Ø70+Ø60	Grease / Oil-air	FANUC Bil 90L/25000	18.5	29.4	Oil	Approx. 105	
REH112		24000	HSK A63	1800~2300		Oil-air				Oil / Pure water		
REH133		24000	HSK A63	1800~2300		Oil-air				Pure water		
RE4064	Ø210	20000	BBT40	1260±60	Ø70+Ø55	Grease	SIEMENS 1FE 1083-4WN11	24.8	63	Pure water	Approx. 160	
REH134			HSK A63	1800~2300		Grease / Oil-air						
RE4168	Ø220	15000	BBT40	1000~1100	Ø70+Ø60	Grease	FANUC 112M/15000(220V)	High winding 11 Low winding 11	High winding 15.4 Low winding 61.8	Oil	Approx. 140	
RE4114	Ø230	20000	BBT40	1260±60	Ø70+Ø60	Oil-air	FANUC aB112L/20000i(220V)	High winding 18.5 Low winding 11.3	High winding 27.2 Low winding 86.8	Oil	Approx. 230	
REH099			HSK A63	1800~2300			ATE AC180/260/4(380V)	26	123.5		Approx. 230	
RE5007	Ø250	10000	BBT50	1900±100	Ø100+Ø70	Grease Oil-air	FANUC Bil132L/14000	High winding 22 Low winding 15	High winding 41.6 Low winding 159	Oil	Approx. 270	
RE5025	Ø310	12000	BBT50	2400±100	Ø100+Ø70	Oil-air	FANUC aB160LL/13000i	High winding 26 Low winding 18.5	High winding 99.3 Low winding 305	Oil	Approx. 410	
REH104		10000	HSK A100	4500~5800								

RE3012

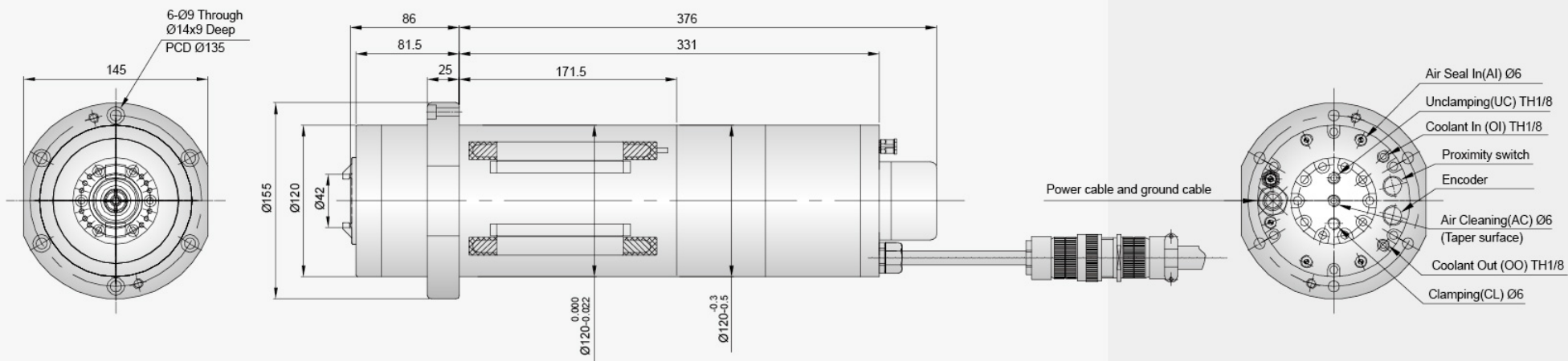

REH135

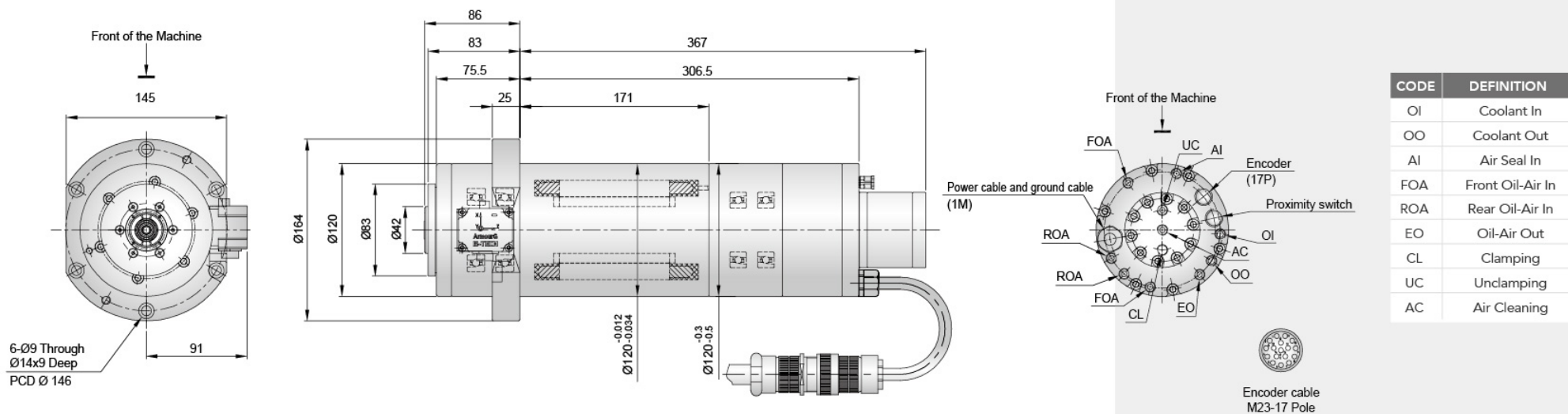

RE4121

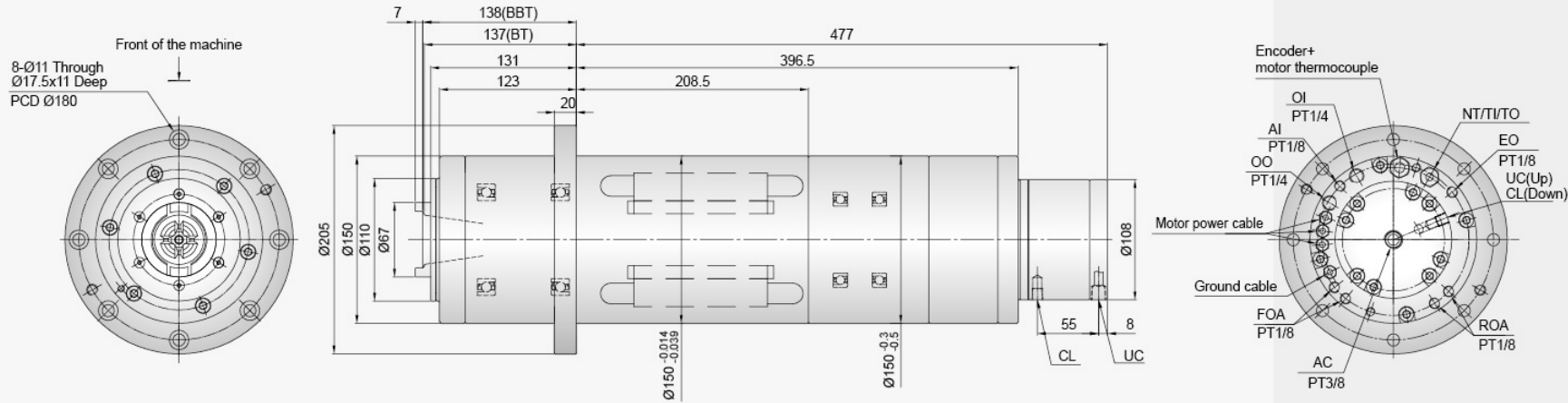

CODE	DEFINITION
OI	Coolant In
OO	Coolant Out
FOA	Front Oil-Air In
ROA	Rear Oil-Air In
EO	Oil-Air Out
AI	Air Seal in
UC	Unclamping
CL	Clamping
AC	Air Cleaning
NT	Without Tool Sensor
TI	Clamping Sensor
TO	Unclamping Sensor

REH112

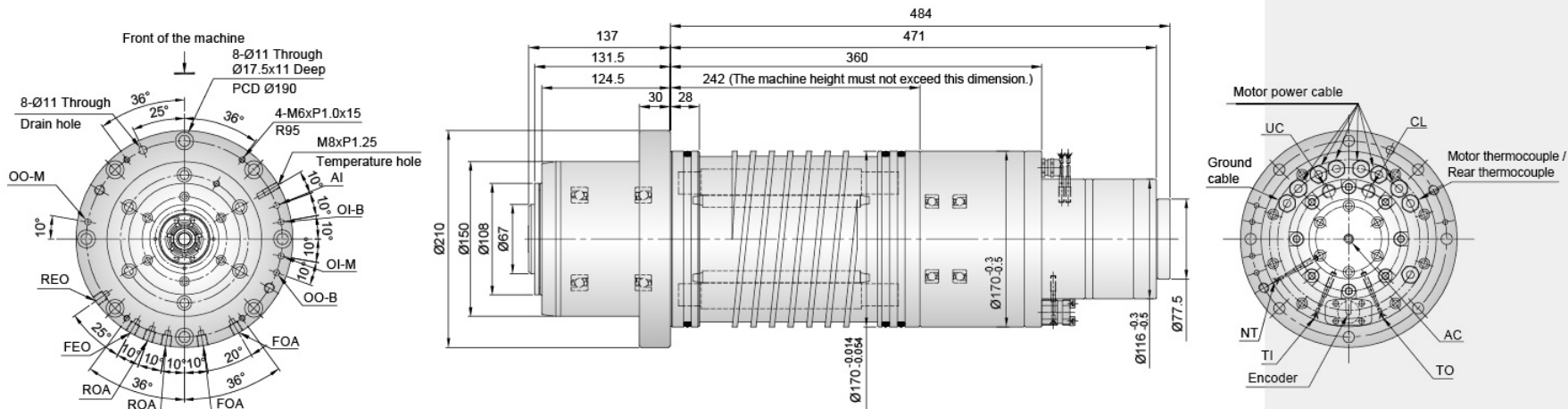

CODE	DEFINITION
OI-B	Bearing Coolant In
OO-B	Bearing Coolant Out
OI-M	Motor Coolant In
OO-M	Motor Coolant Out
AI	Air Seal In
FOA	Front Oil-Air In
ROA	Rear Oil-Air In
FEO	Front Oil-Air Out
REO	Rear Oil-Air Out
CL	Clamping
UC	Unclamping
TI	Clamping Sensor
TO	Unclamping Sensor
NT	Without Tool Sensor

REH133

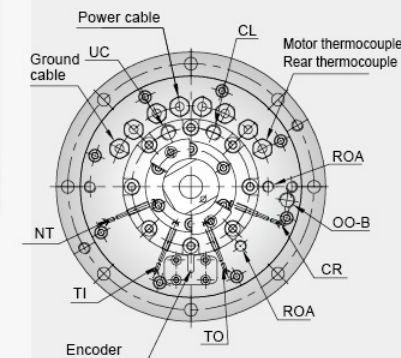
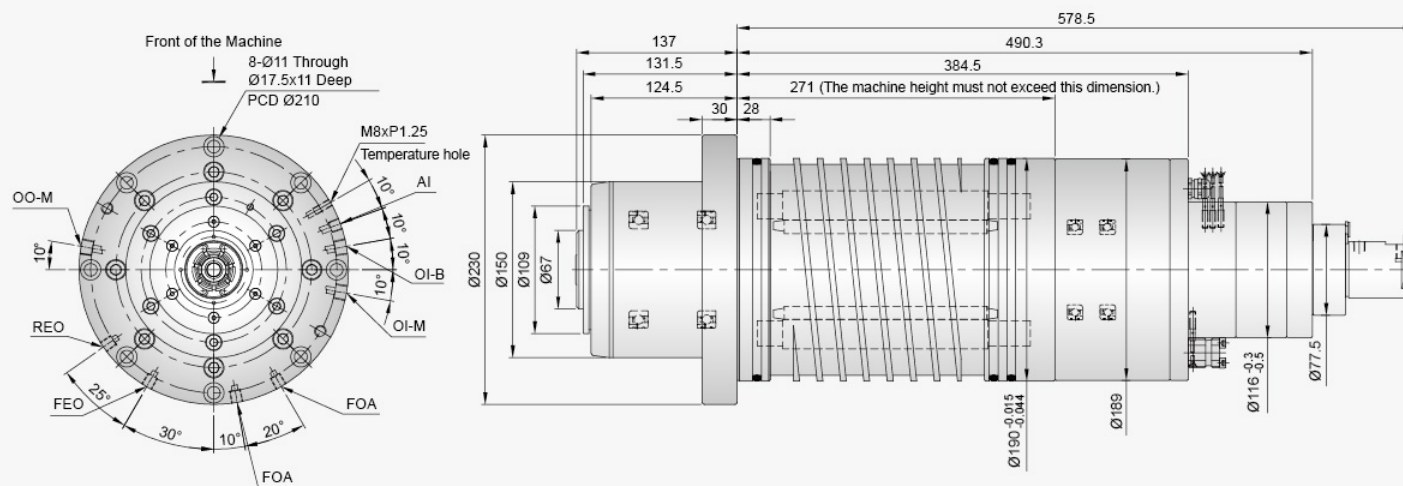

CODE	DEFINITION
OI-B	Bearing Coolant In
OO-B	Bearing Coolant Out
OI-M	Motor Coolant In
OO-M	Motor Coolant Out
AI	Air Seal In
FOA	Front Oil-Air In
ROA	Rear Oil-Air In
FEO	Front Oil-Air Out
REO	Rear Oil-Air Out
CL	Clamping
UC	Unclamping
TI	Clamping Sensor
TO	Unclamping Sensor
NT	Without Tool Sensor
CR	Cylinder Return

REH134

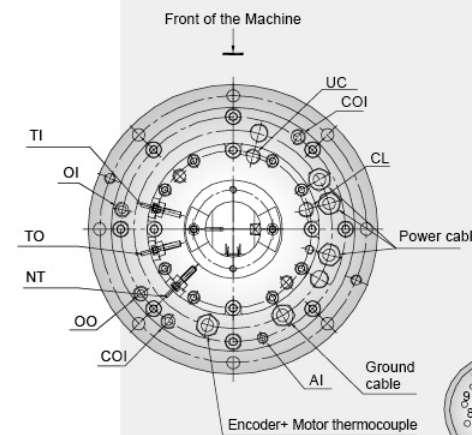
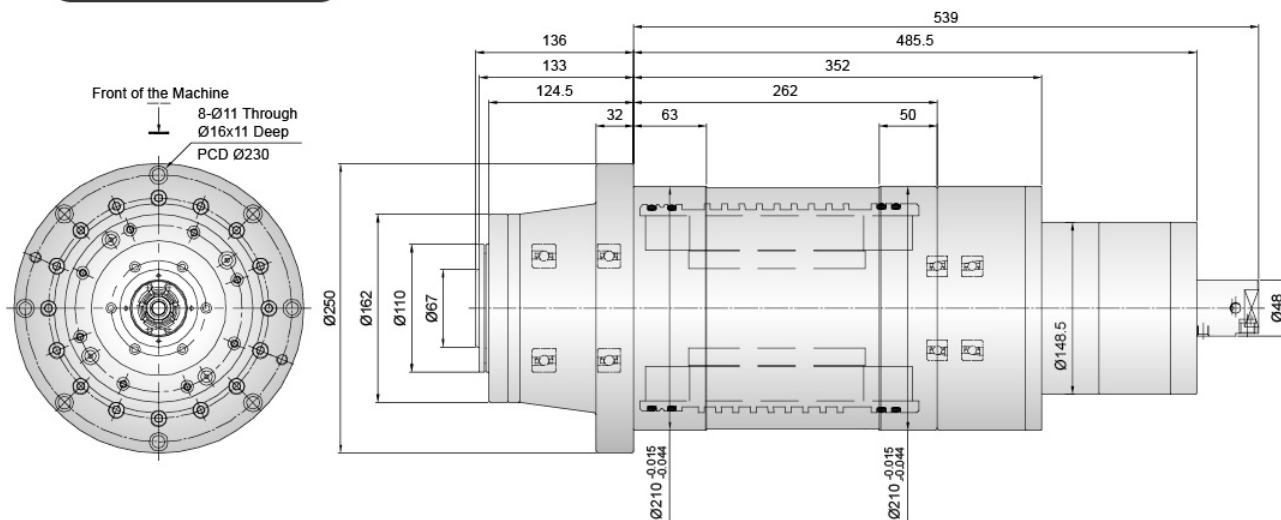

CODE	DEFINITION
OI	Coolant In
OO	Coolant Out
AI	Air Seal In
UC	Unclamping
CL	Clamping
COI	Cutting Coolant In
TI	Clamping Sensor
TO	Unclamping Sensor
NT	Without Tool Sensor



Encoder cable
M23-17 Pole

RE4168

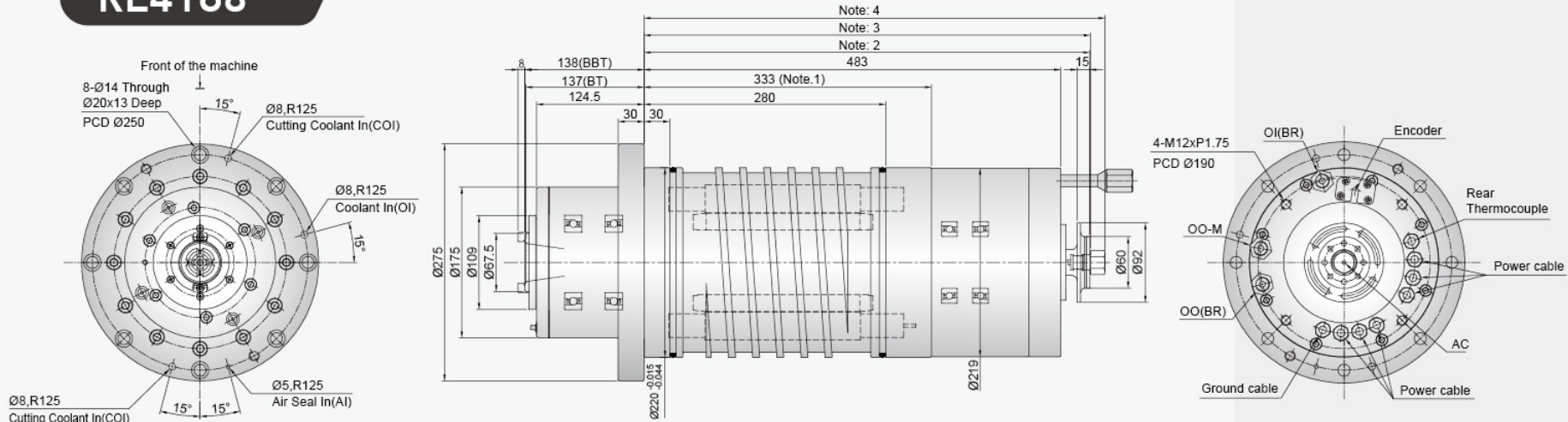

CODE	DEFINITION
OI(BR)	Coolant In(Rear bearing)
OO(BR)	Coolant Out(Rear bearing)
OO-M	Coolant Out(Motor)
AC	Air Cleaning

- Note: 1. The machine height must not exceed this dimension.
 2. 519 (without tool), 516.9 (clamping), 511.3 (Unclamping, including an ejection of 0.6mm) (Clamping position for CTS)
 3. 519.5 (without tool), 517.4 (clamping), 511.8 (Unclamping, including an ejection of 0.6mm) (Installation position of rotary joint)
 4. 536.5 (without tool), 534.4 (clamping), 528.8 (Unclamping, including an ejection of 0.6mm) (Clamping position for Standard (non-CTS))

RE4114

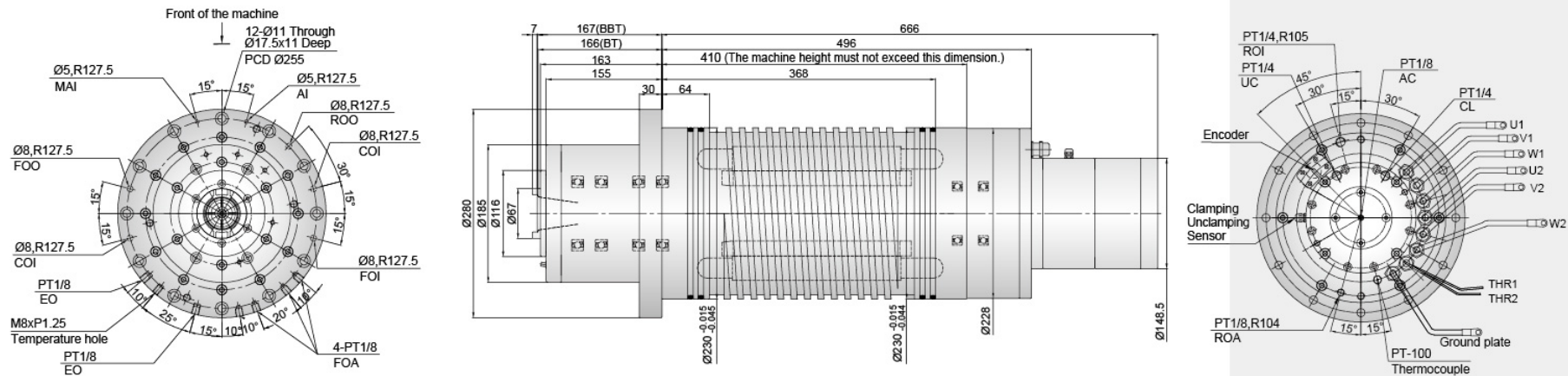

CODE	DEFINITION
FOI	Front Bearing Coolant In
FOO	Front Bearing Coolant Out
ROI	Rear Bearing Coolant In
ROO	Rear Bearing Coolant Out
COI	Cutting Coolant In
AI	Air Seal In
MAI	Motor Coolant In
FOA	Front Oil-Air In
ROA	Rear Oil-Air In
EO	Oil-Air Out
UC	Unclamping
CL	Clamping
AC	Air Cleaning

RE5007

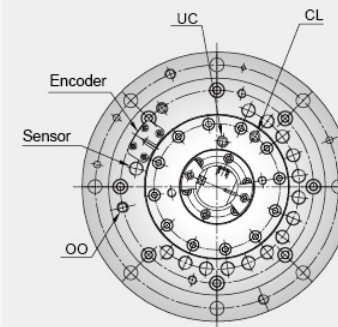
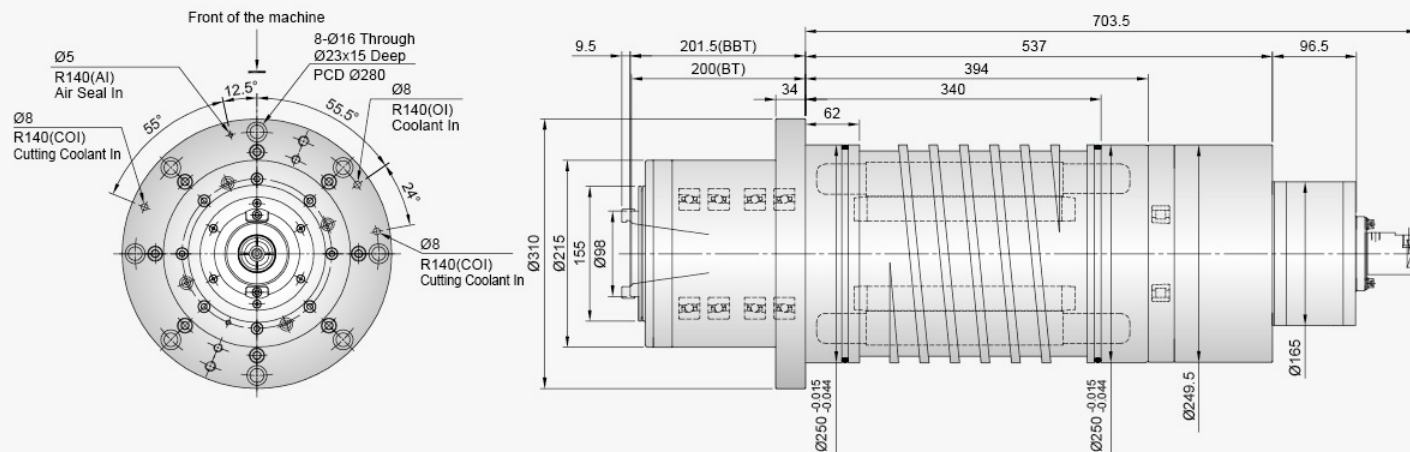

CODE	DEFINITION
CL	Clamping
UC	Unclamping
OO	Coolant Out

RE5025

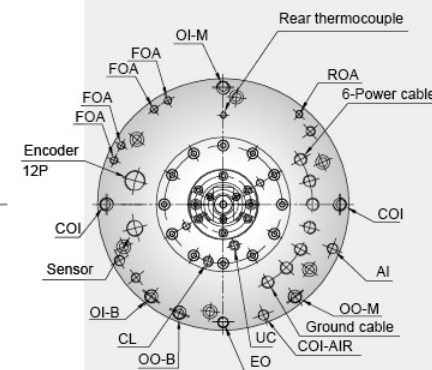
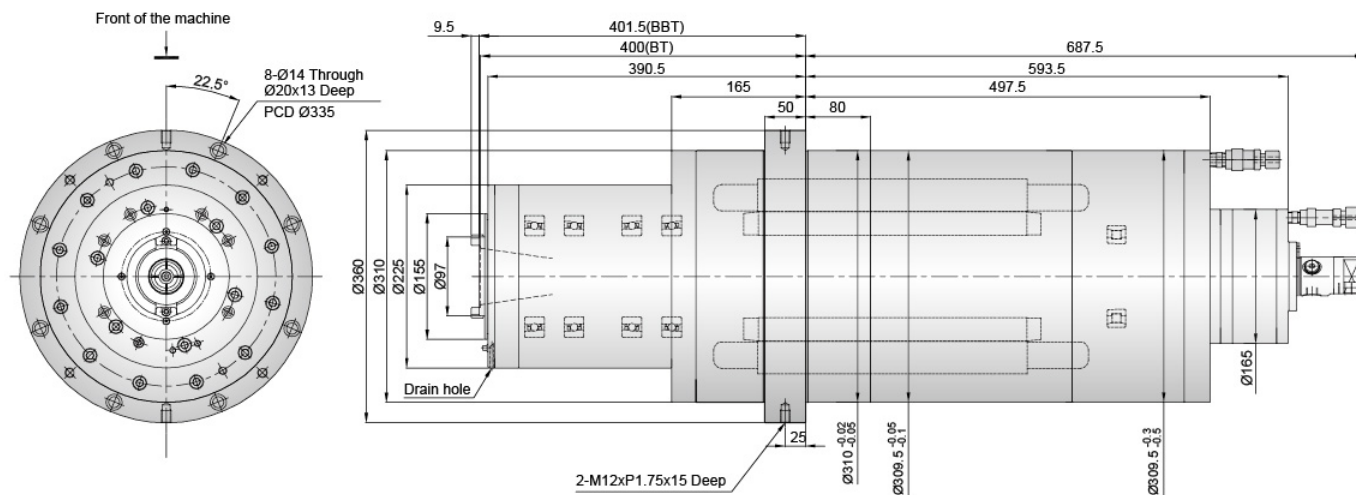

CODE	DEFINITION
COI	Cutting Coolant In
COI-AIR	Cooling Air In
OI-B	Bearing Coolant In
OO-B	Bearing Coolant Out
OI-M	Motor Coolant In
OO-M	Motor Coolant Out
AI	Air Seal In
FOA	Front Oil-Air In
ROA	Rear Oil-Air In
EO	Oil-Air Out
CL	Clamping
UC	Unclamping

Direct-Drive Spindle

- ▶ High dynamic rotary accuracy
- ▶ High precision, low vibration
- ▶ Same flange dimensions, high adaptability

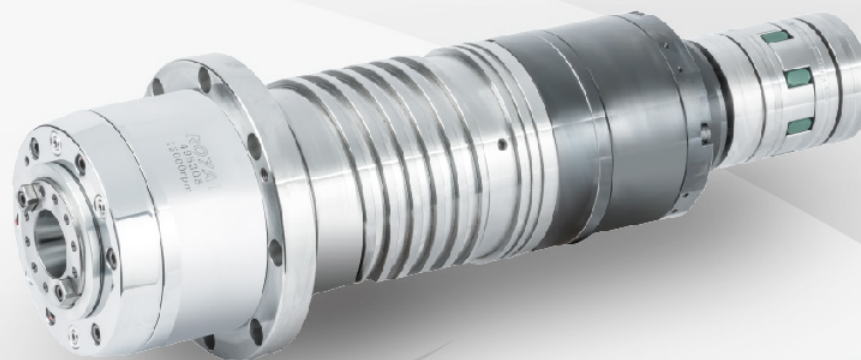

Model	Housing OD (mm)	Max. Speed (rpm)	Taper	Clamping force (kgf)	Bearing ID (mm)	Lubrication	Cooling	Weight (kg)	CTS
RD3068	Ø100	24000	BT30/BBT30	250±50	Ø40	Grease Oil-air	Oil	Approx. 38	Optional
RD3006	Ø120	18000	BT30/BBT30	350±50	Ø60			Approx. 38	
RD4172		15000	BT40/BBT40	900±100	Ø60			Approx. 38	
RDH085	Ø150	12000	HSK A63	1800~2300	Ø60			Approx. 38	
RD4230			BT40/BBT40	1200~1320	Ø70			Approx. 60	
RD4152			BT40/BBT40	1200±100	Ø70			Approx. 60	
RDH069	Ø155	18000	HSK A63	1800~2300	Ø70			Approx. 60	
RD4014			BT40/BBT40	1000±100	Ø70			Approx. 80	
RD5012	Ø190	10000	BT50/BBT50	1500±100	Ø80			Approx. 70	
RD5002			BT50/BBT50	1800±100	Ø90			Approx. 112	
RDH061			HSK A100	4500~5800	Ø90			Approx. 112	
RD5059	Ø200	12000	BT50/BBT50	1800±100	Ø100			Approx. 134	
RDH008			HSK A100	4500~5800	Ø100			Approx. 134	

RD3006

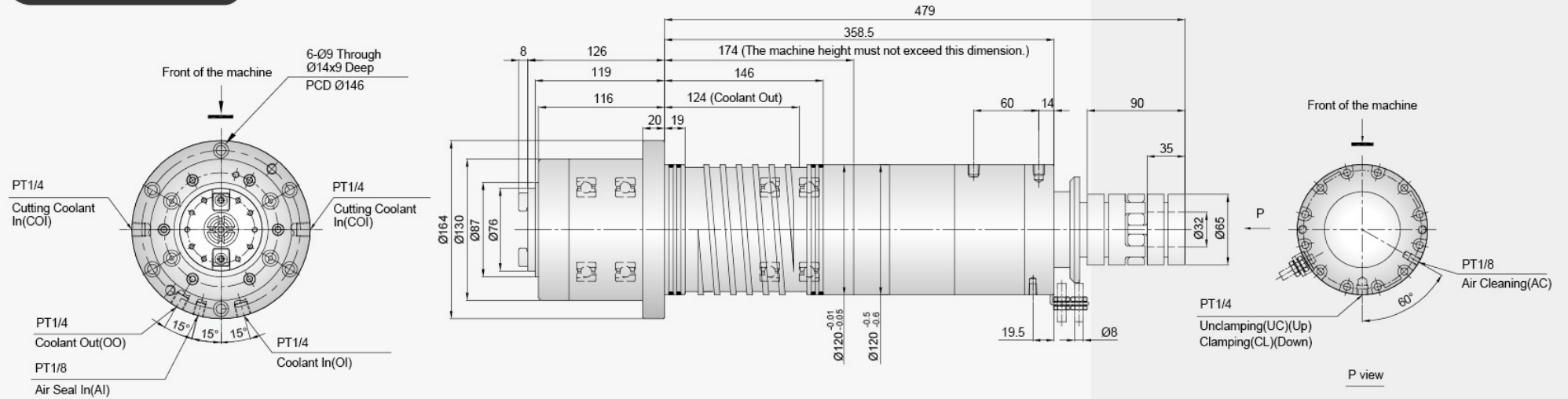

RD4172

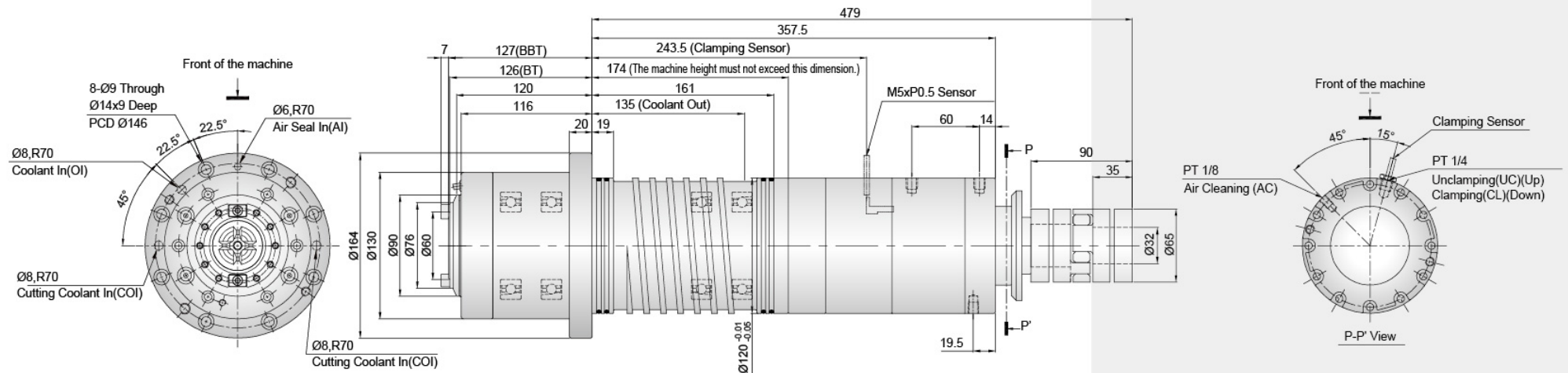

RD4152

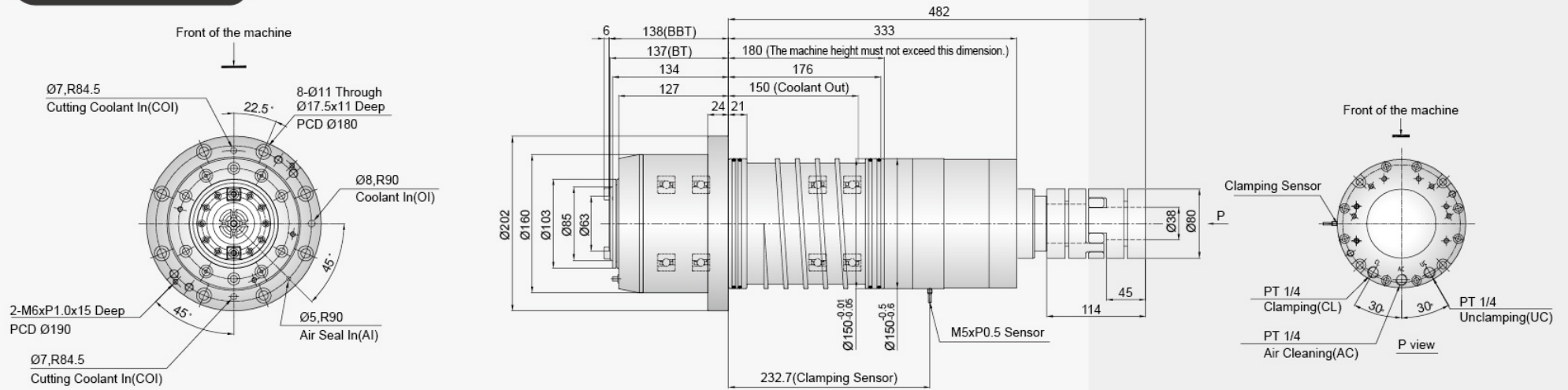

RDH069

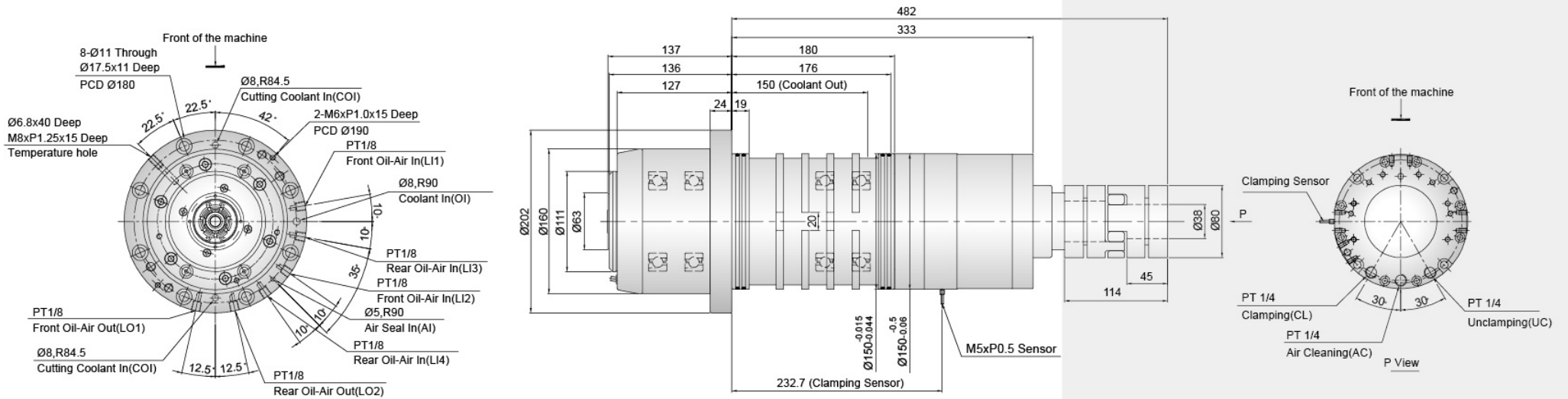

RD4230

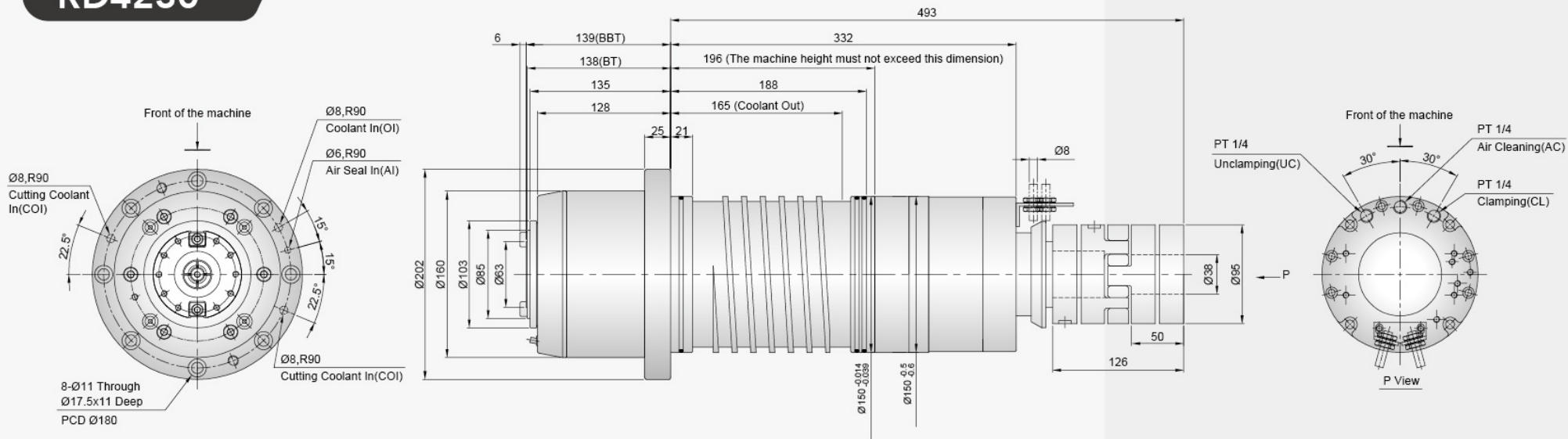

RD5002

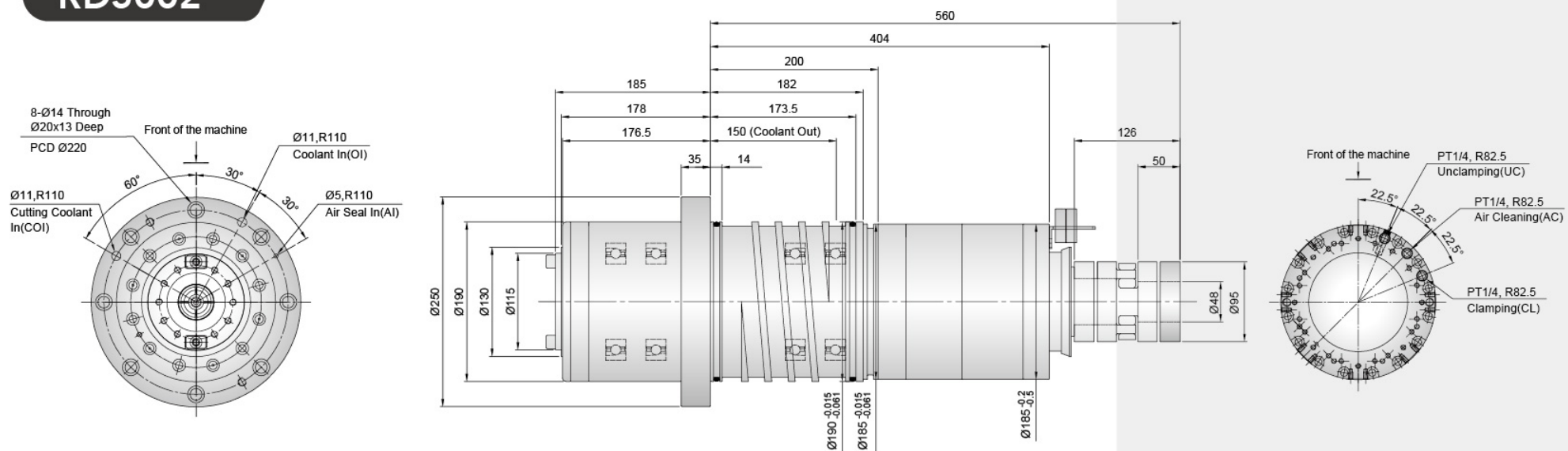

Belt-Drive Spindle

- ▶ High precision, high rigidity
- ▶ Easy repair, simple maintenance



Model	Housing OD (mm)	Max. Speed (rpm)	Taper	Clamping force (kgf)	Bearing ID (mm)	Lubrication	Cooling	Weight (kg)	CTS
RB3002	Ø100	15000	BT30/BBT30	300±50	Ø50	Grease	Oil	Approx. 17	Optional
RB3021	Ø120	15000	BT30/BBT30	300±50	Ø60			Approx. 20	
RB4006		12000	BT40/BBT40	700±50	Ø60			Approx. 33	
RB4388	Ø150	12000	BT40/BBT40	1000±100	Ø70			Approx. 56	
RBH004			HSK A63	1800~2300	Ø70			Approx. 56	
RB4078	Ø155	12000	BT40/BBT40	1000±100	Ø70			Approx. 60	
RBH018			HSK A63	1800~2300	Ø70			Approx. 60	
RB5233	Ø190	8000	BT50/BBT50	1500±100	Ø80			Approx. 70	
RB5004		10000	BT50/BBT50	1800±100	Ø100			Approx. 123	
RB5242		Ø200	10000	BT50/BBT50	1800±100			Ø100	

RB3002

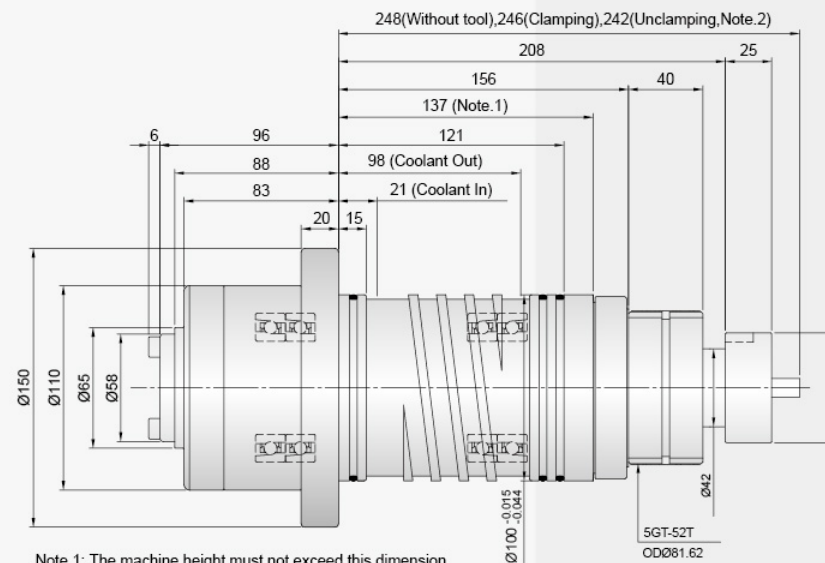
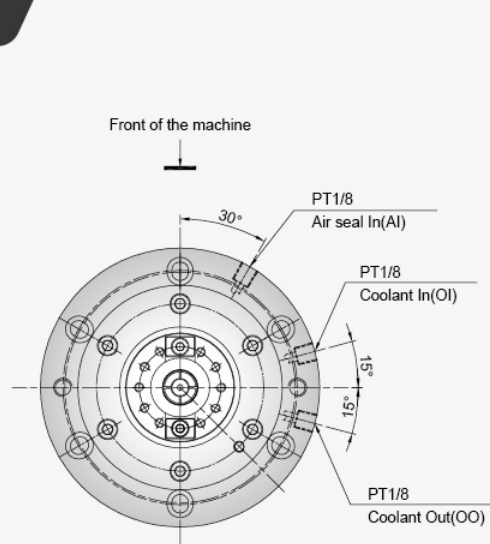

Note.1: The machine height must not exceed this dimension.
 Note.2: including an ejection of 0.5mm.

RB4006

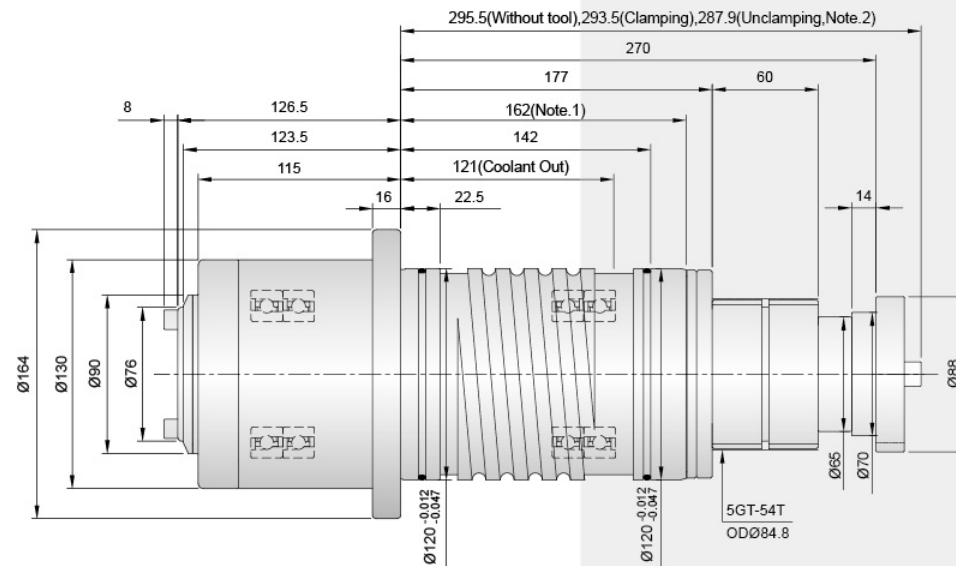
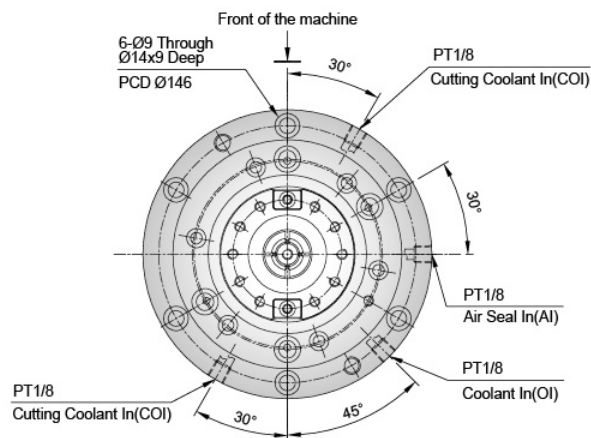

Note.1: The machine height must not exceed this dimension.
 Note.2: including an ejection of 0.6mm.

RB4388

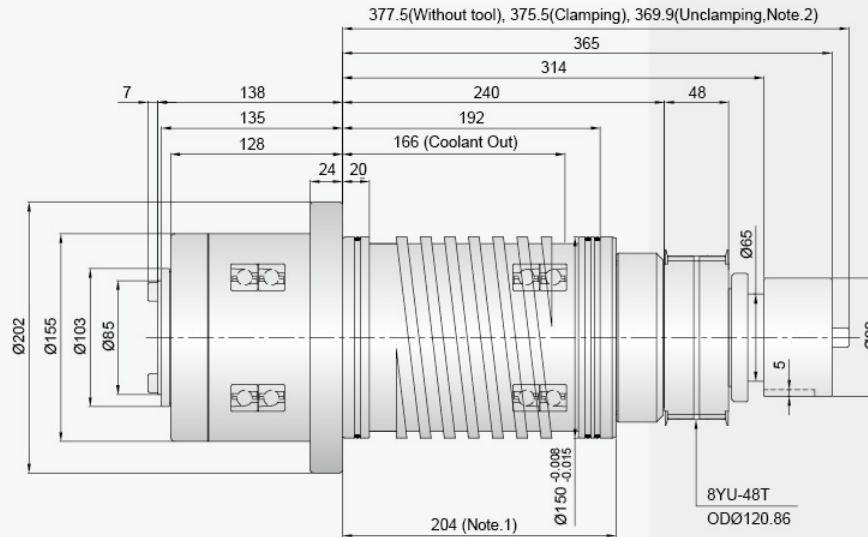
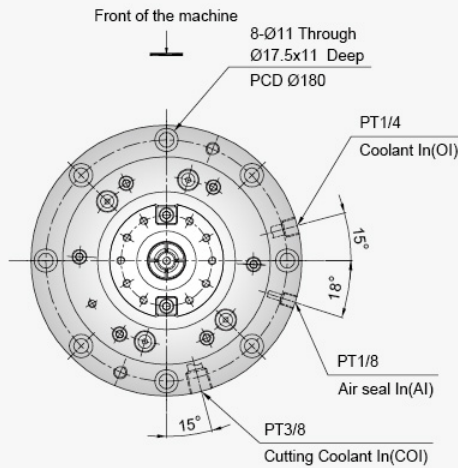

Note.1: The machine height must not exceed this dimension.
 Note.2: including an ejection of 0.6mm.

RB4078

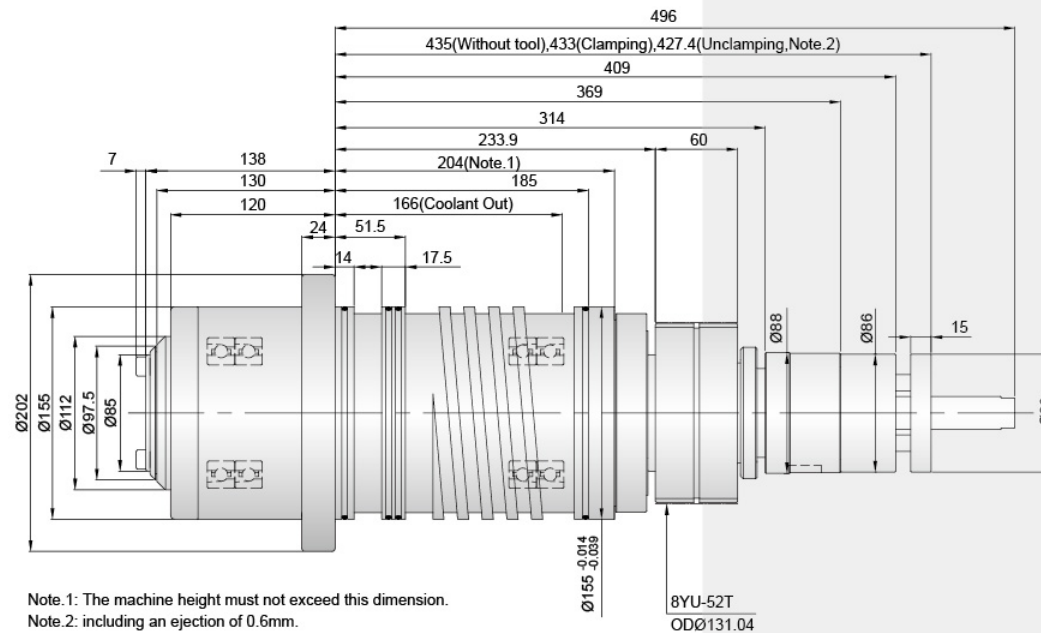
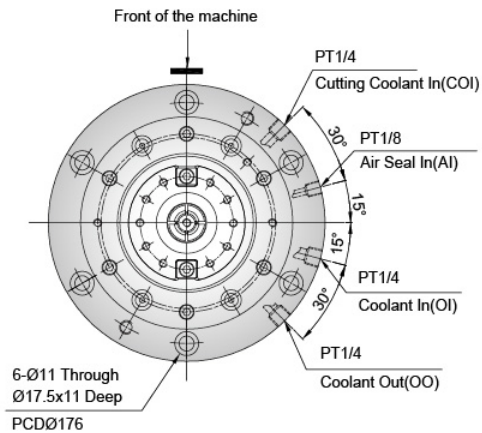

Note.1: The machine height must not exceed this dimension.
 Note.2: including an ejection of 0.6mm.

RB5233

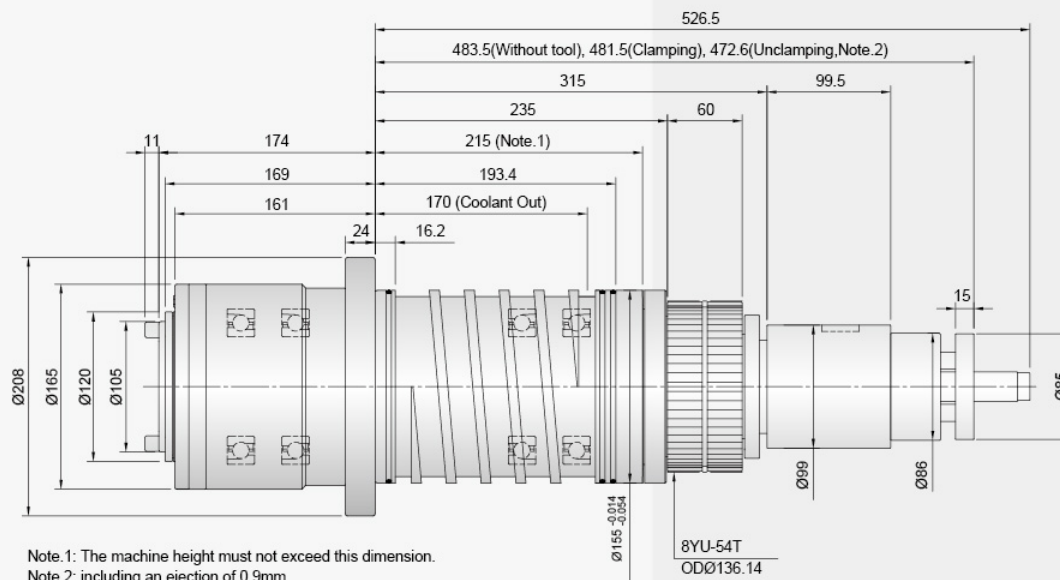
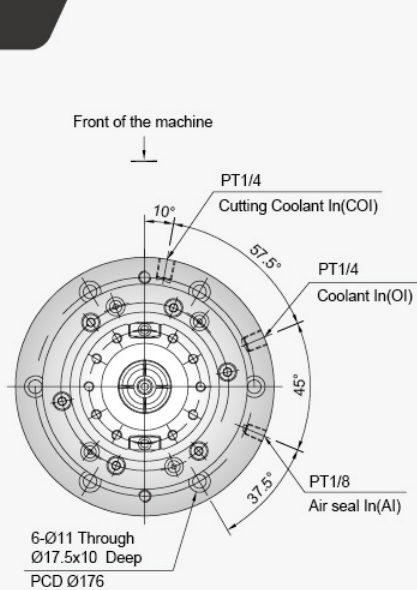

Note.1: The machine height must not exceed this dimension.
Note.2: including an ejection of 0.9mm.

RB5004

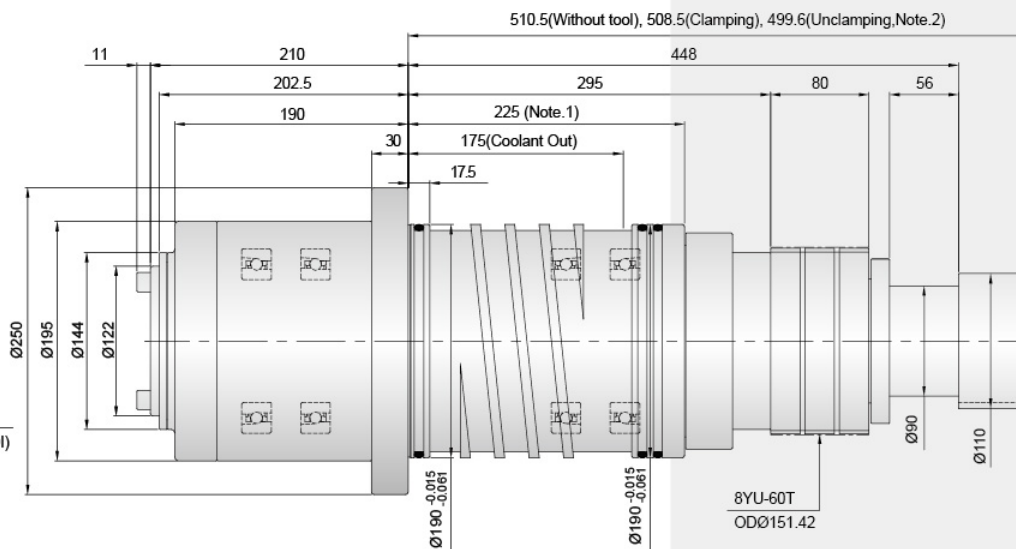
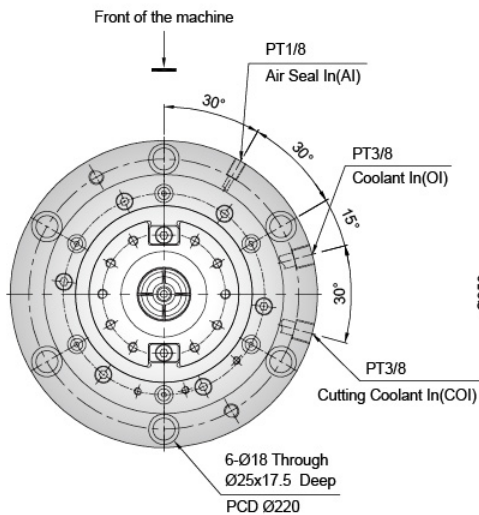

Note.1: The machine height must not exceed this dimension.
Note.2: including an ejection of 0.9mm.

Gear-Drive Spindle

- ▶ High torque transmission
- ▶ High cutting efficiency

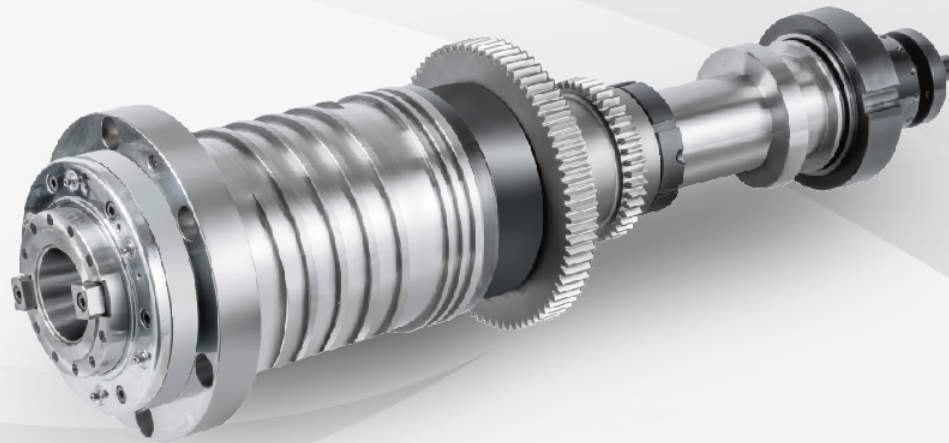

Model	Housing OD (mm)	Max. Speed (rpm)	Taper	Clamping force (kgf)	Bearing ID (mm)	Lubrication	Cooling	Weight (kg)	CTS
RT4002	Ø150	8000	BT40	1000±100	Ø70	Grease	Oil	Approx. 65	Optional
RT5006	Ø190	8000	BT50	1800±100	Ø100			Approx. 110	

RT4002

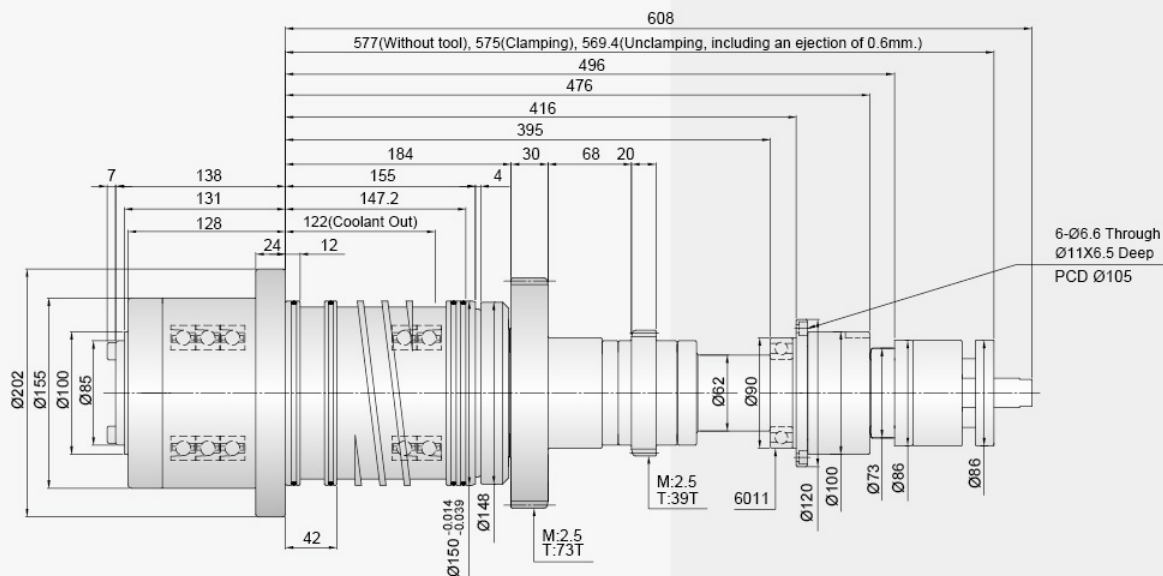
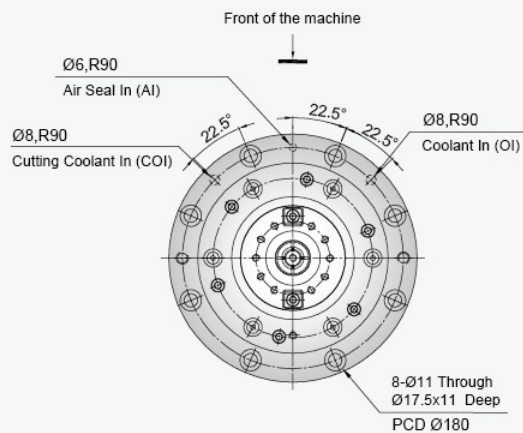

RT5006

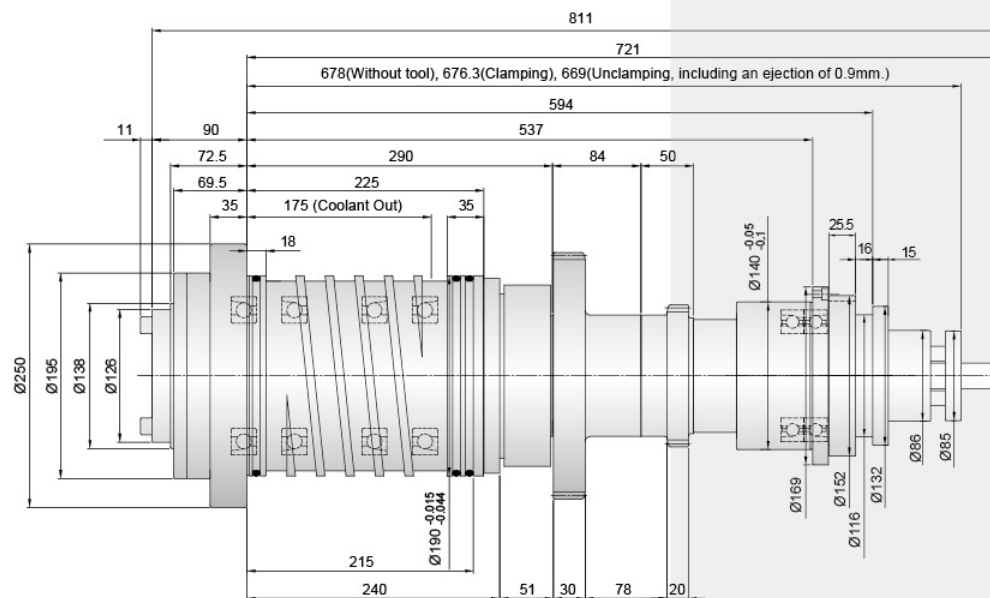
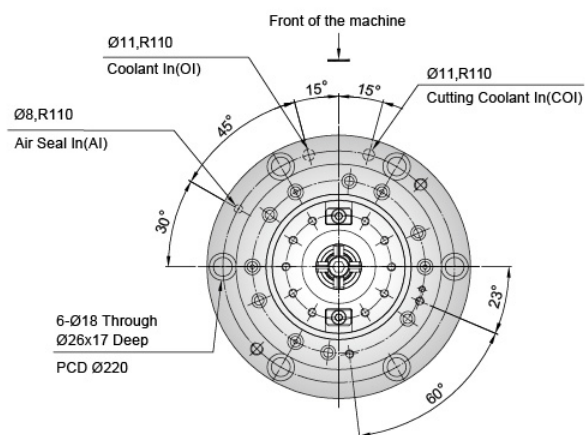

Motorized Spindle

High Precision

- ▶ High dynamic rotary accuracy
- ▶ Balancing adjustment within G1, low vibration
- ▶ Modularized easily
- ▶ Low thermal displacement, high stability
- ▶ Short overall length, low inertia

High Efficiency

- ▶ High motor power, high moments of inertia



Model	Housing OD (mm)	Max. Speed (rpm)	Nose	Spindle Bore Hole (mm)	Bearing ID (mm)	Lubrication	Motor Specification	Power S1 (kW)	Torque S1 (Nm)	Cooling	Weight (kg)	Options
REA506	Ø185	6000	A2-5	56.5	Ø90+Ø75	Grease	160/110/220(380V)	11	74.9	Oil	Approx. 250	Brake Disc
REA613	Ø290	5000	A2-6	76.3	Ø120+Ø100		SIMENS 1FE1114-6WW31	18.6	200		Approx. 230	
REA609	Ø345	4500	A2-6	76	Ø140+Ø115		FANUC Bil 200M/6000-B(200V)	18.5	343		Approx. 365	
REA813	Ø340	4000	A2-8	91	Ø140+Ø115		ATE AC 270/250/8	18.5	430.9		Approx. 360	

REA506

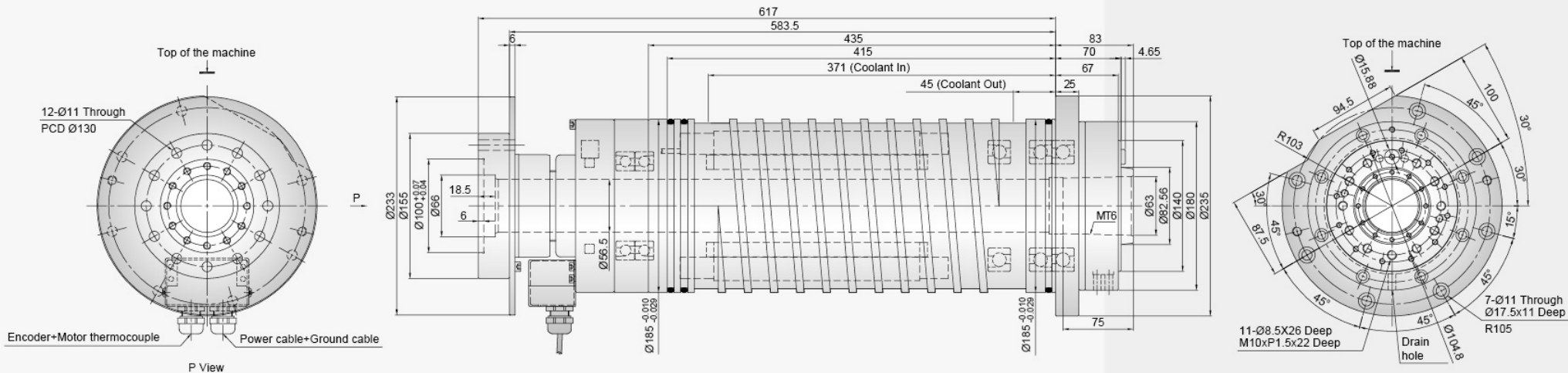

REA613

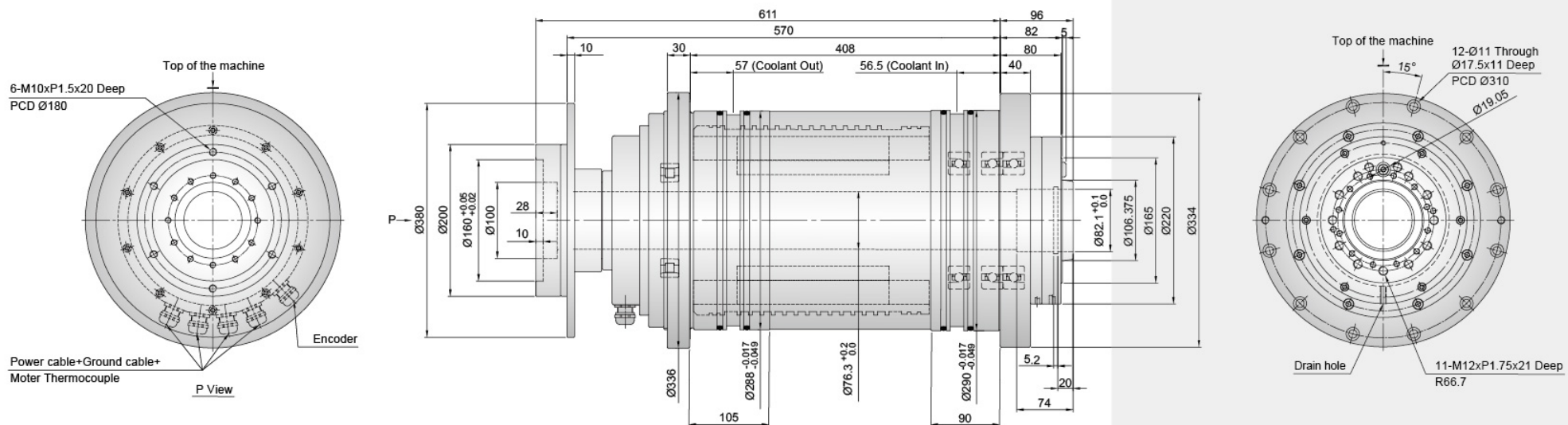

REA609

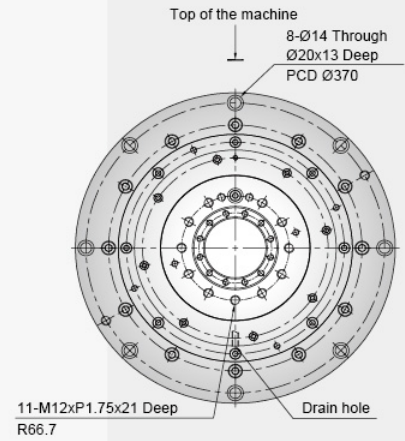
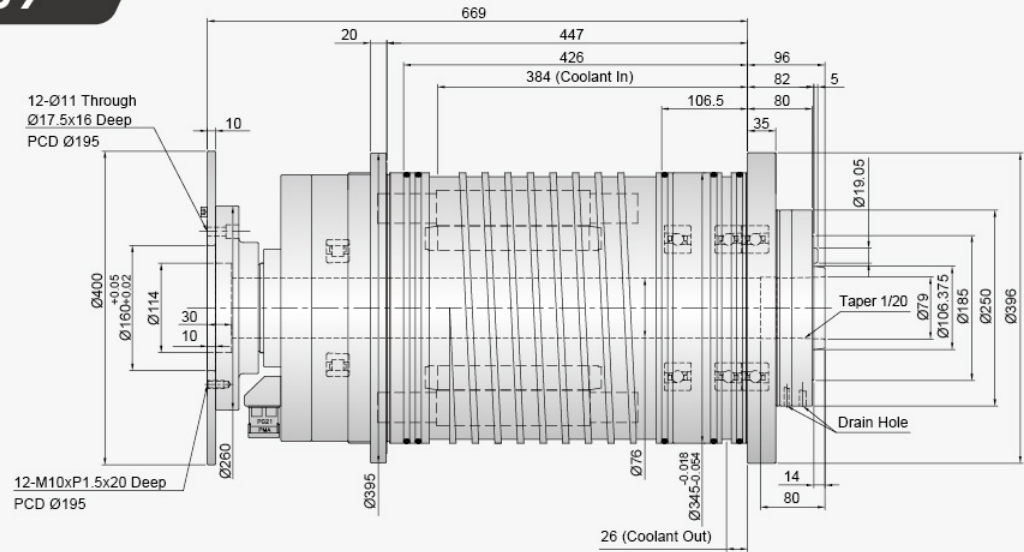

REA813

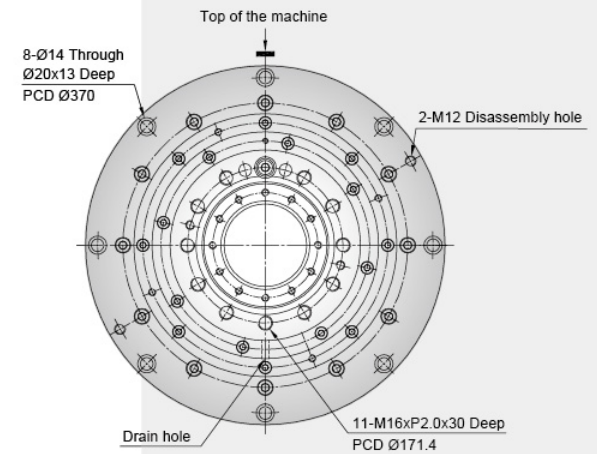
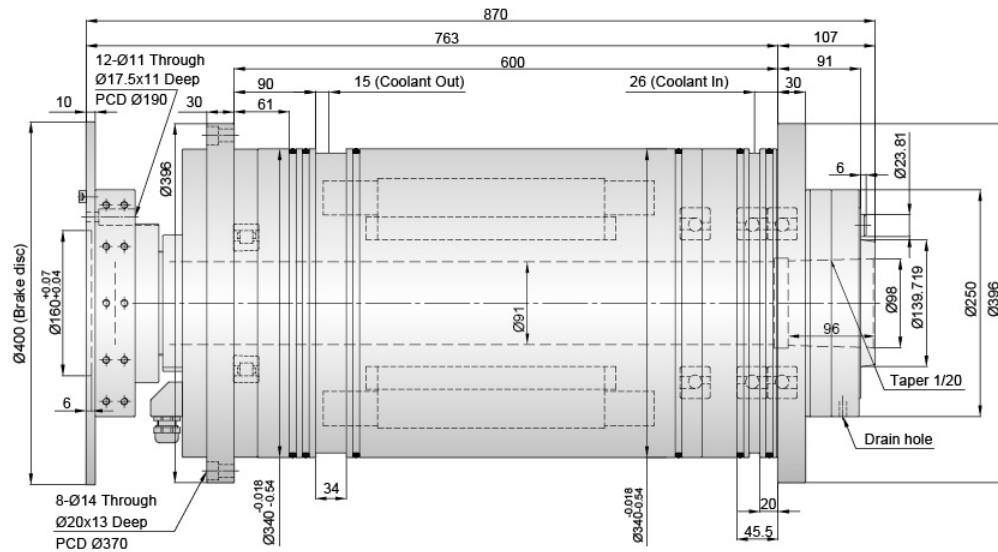

Belt-Drive Spindle

- ▶ High dynamic rotary accuracy
- ▶ High axial and radial rigidity
- ▶ Stable thermal temperature

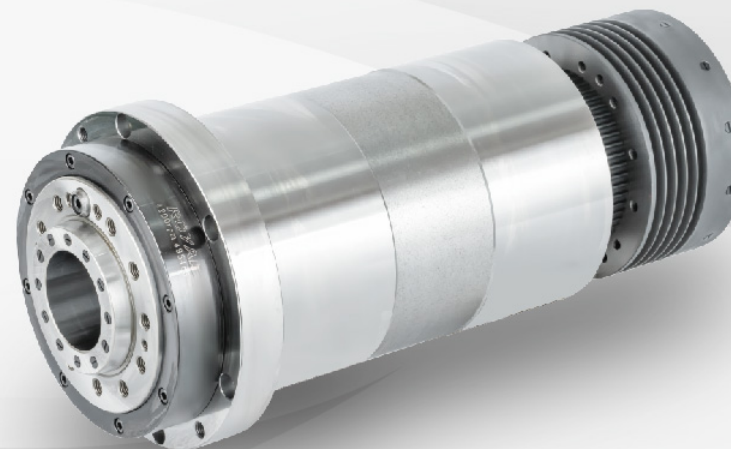

Model	Housing OD (mm)	Max. Speed (rpm)	Nose	Spindle Bore Hole (mm)	Bearing ID (mm)	Lubrication	Weight (kg)	Options
RA4007	Ø150	8000	A2-4	45	Ø70	Grease	Approx. 47	Brake Disc Encoder
RA5005	Ø170	6000	A2-5	56	Ø80		Approx. 75	
RA6023	Ø200	5000	A2-6	66	Ø100+Ø90		Approx. 90	
RA8001	Ø260	3500	A2-8	92/98	Ø130+Ø120		Approx. 200	
RA1113	Ø286	2800	A2-11	117.5	Ø160+Ø150		Approx. 313	
RA1503	Ø400	1000	A2-15	184	Ø240+Ø220		Approx. 610	

RA4007

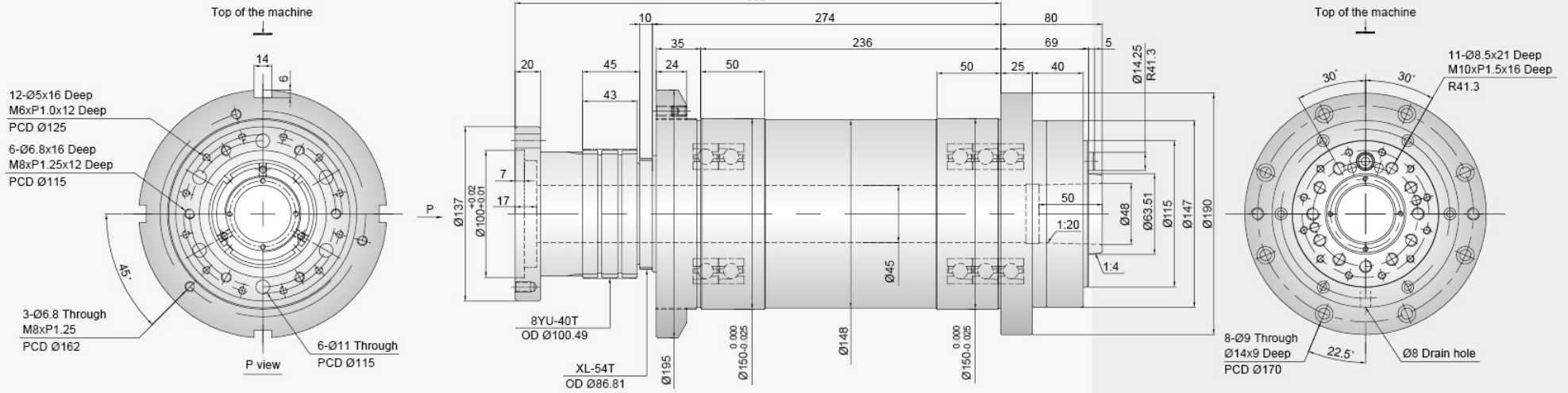

RA5005

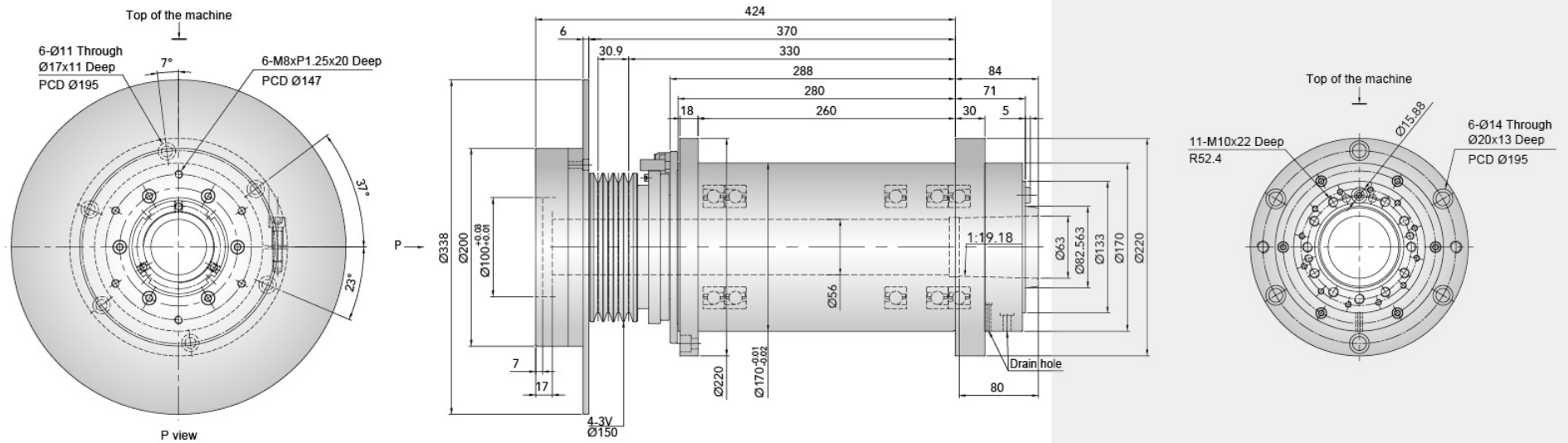

RA6023

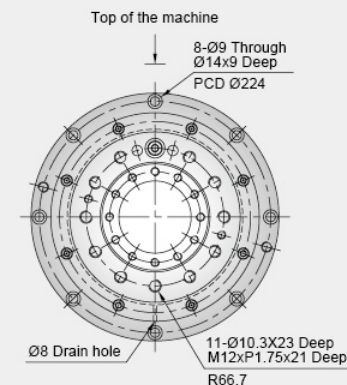
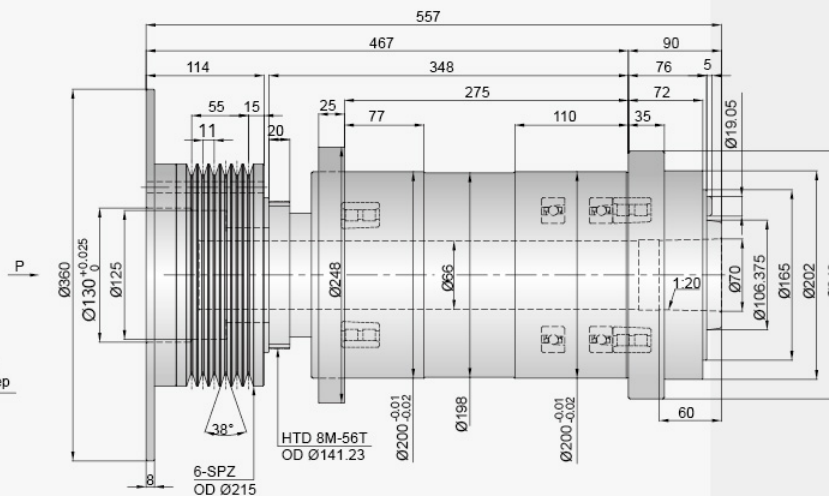
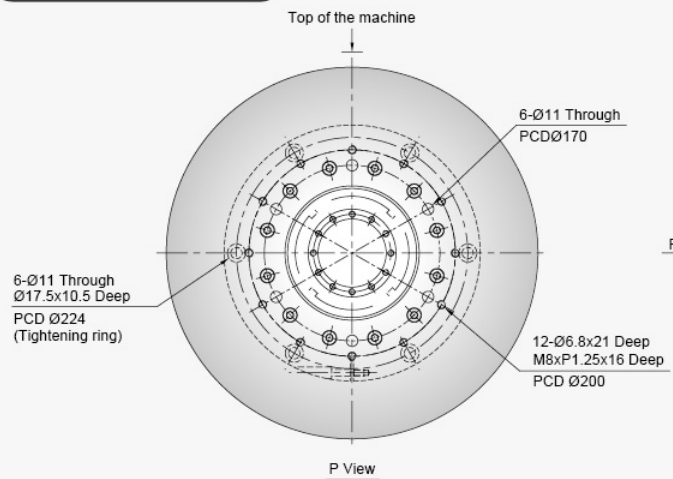

RA8001

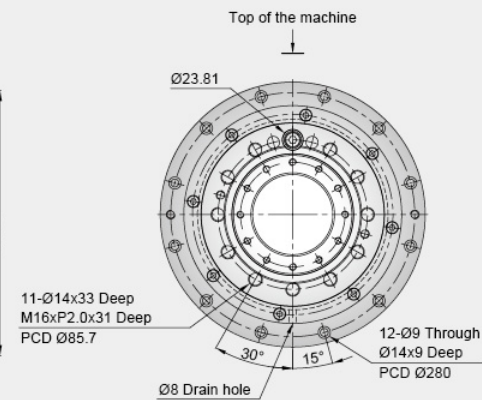
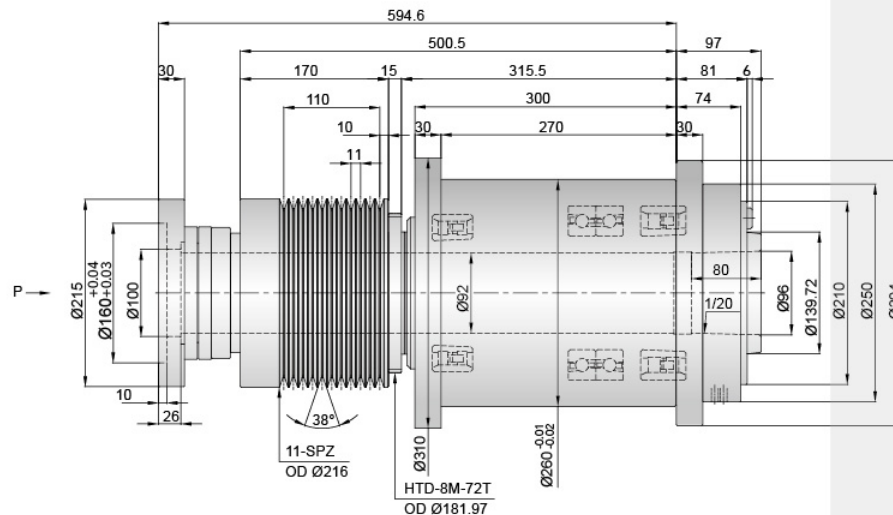
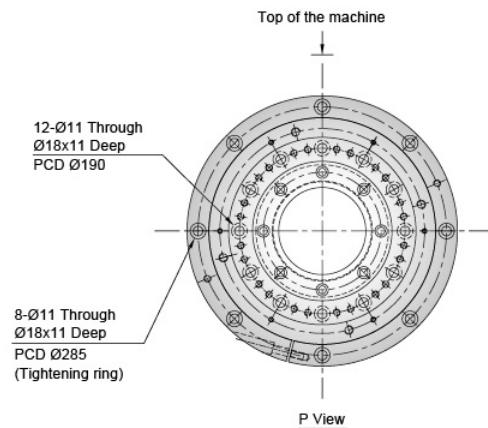

RA1113

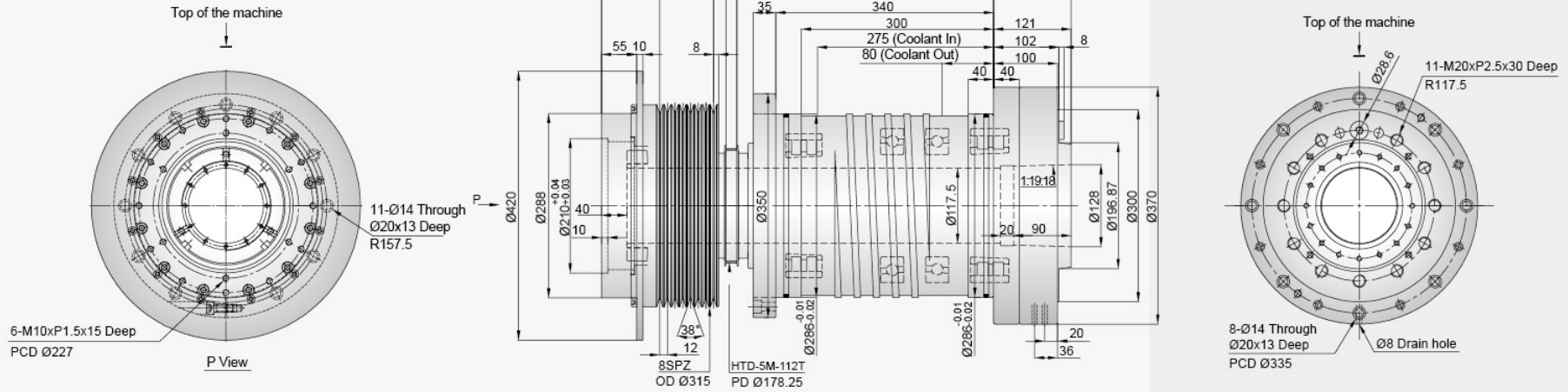

RA1503

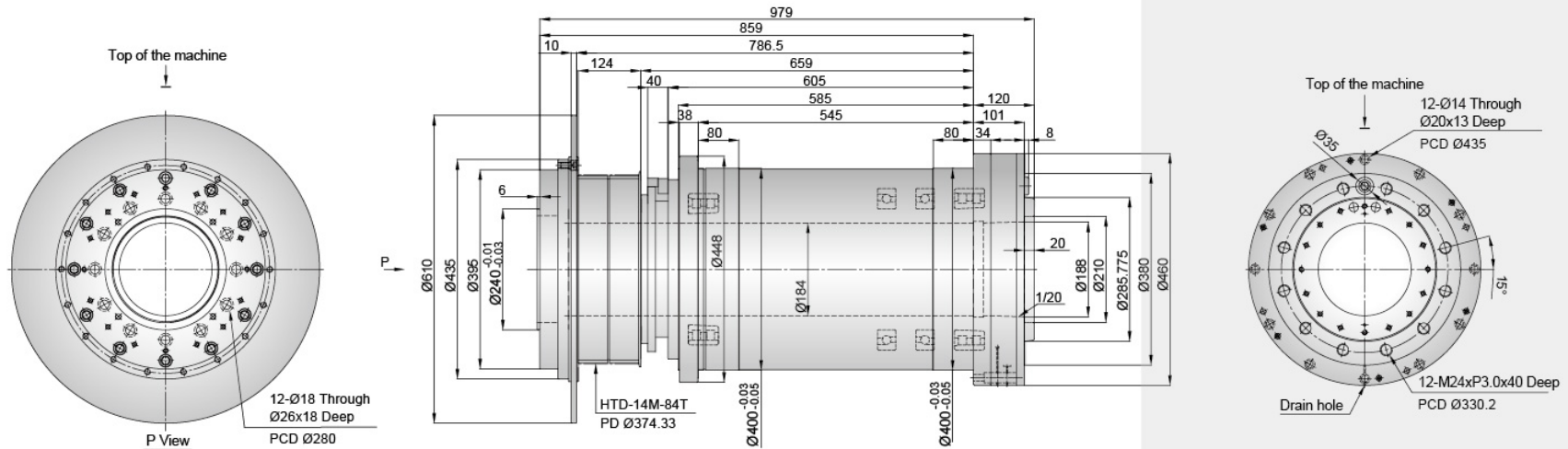

Direct-Drive Spindle

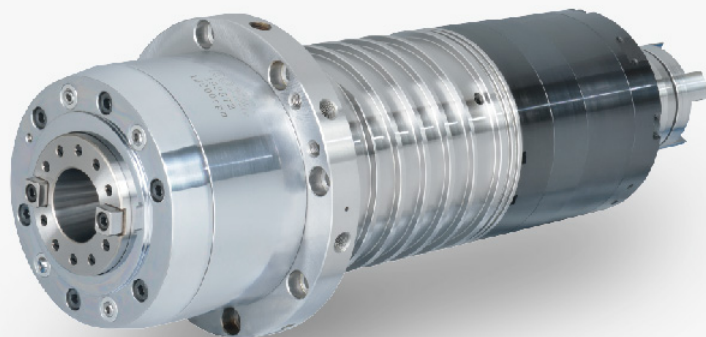

Model	Housing OD (mm)	Max. Speed (rpm)	Taper	Clamping force (kgf)	Bearing ID (mm)	Lubrication	Cooling	Weight (kg)	CTS
RD4187	Ø150	12000	BBT40	1200~1320	Ø70	Grease	Oil	Approx. 58	Optional

RD4187

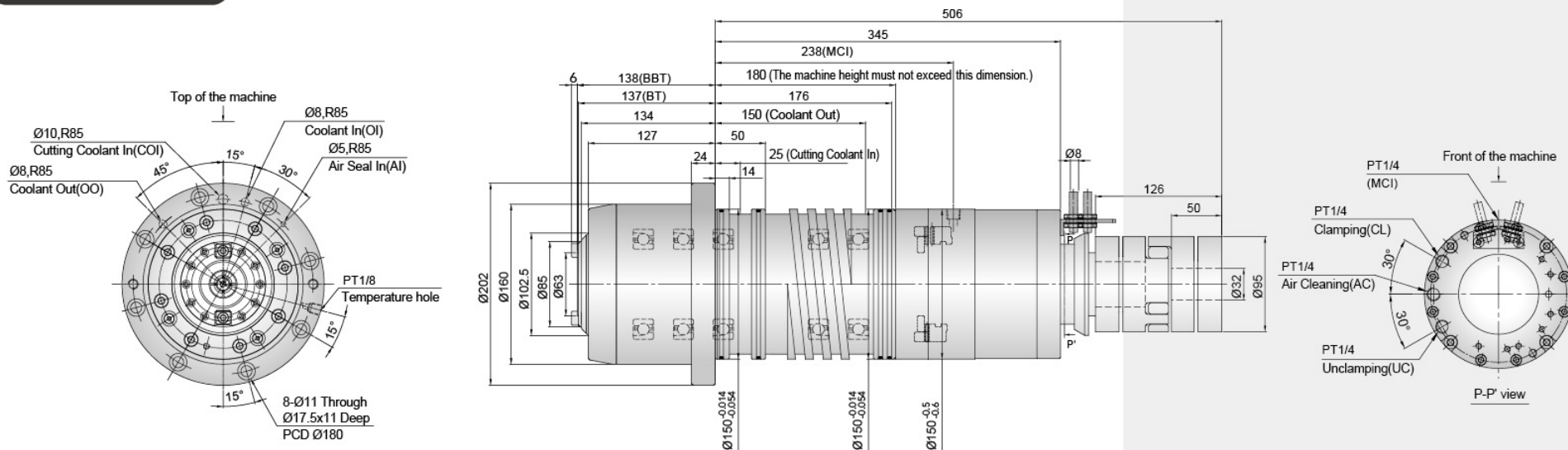

Motorized Spindle

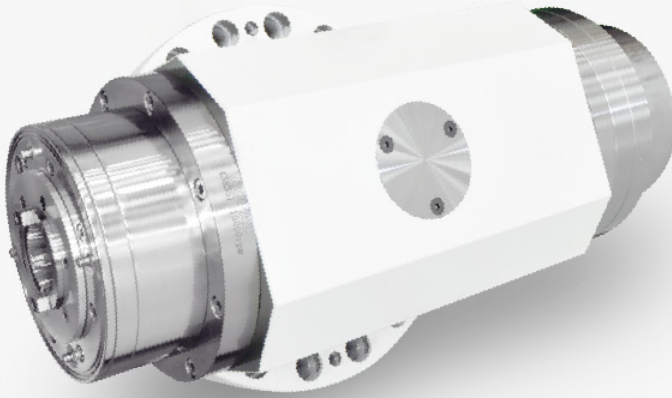

Model	Housing OD (mm)	Max. Speed (rpm)	Taper	Clamping force (kgf)	Bearing ID (mm)	Lubrication	Motor Specification	Power S1 (kW)	Torque S1 (Nm)	Cooling	Weight (kg)	CTS
RE4125	Ø210	15000	BBT40	1200±100	Ø70	Grease	ATE AC 160/170/8(380V)	15	71.6	Oil	Approx. 152	Optional
REH128		15000	HSK A63	1800~2300	Ø70		ATF IM160/170/6(380V)	28.3	60.1		Approx. 170	
REH098	Ø235	15000	HSK A63	1800~2300	Ø70		SIEMENS 1FE 1093-4WN11	19.6	75		Approx. 170	

RE4125

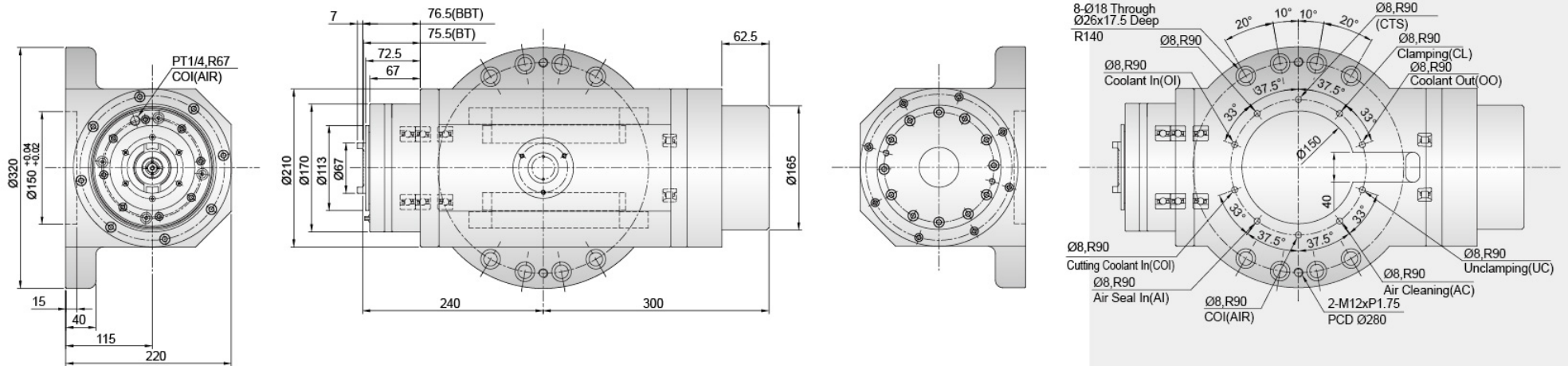

Direct-Drive Spindle



Model	Housing OD (mm)	Max. Speed (rpm)	Bearing ID (mm)	Lubrication	Weight (kg)
RG0024	Ø130	3000	Ø65	Grease	Approx. 80

RG0024

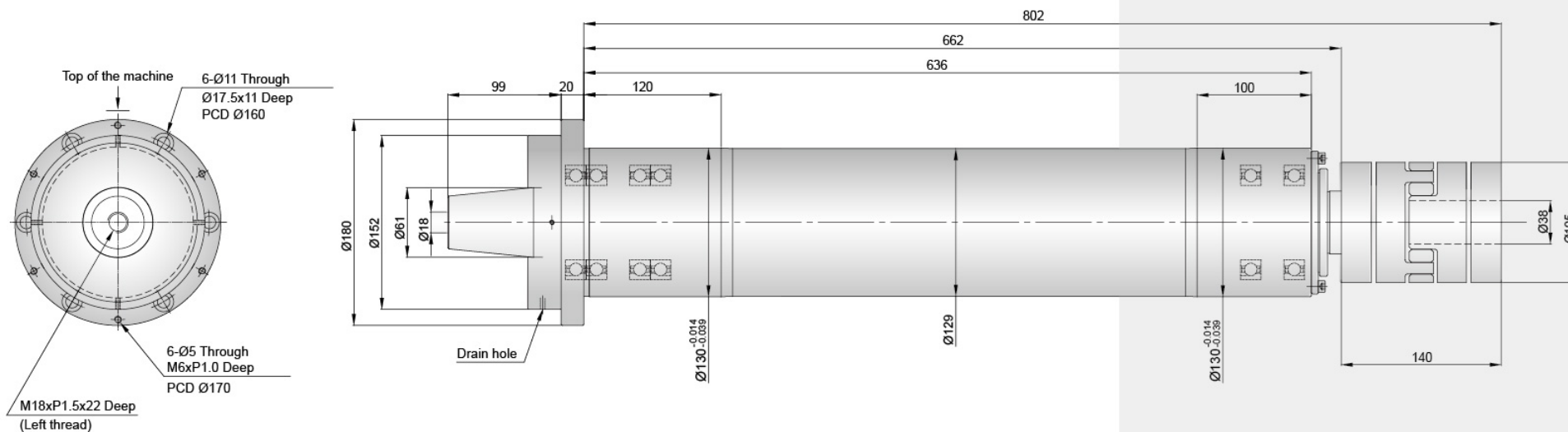

Your Spindle Solutions
Speed, Precision, Rigidity

ROYAL

Royal Precision Tools Corporation

Head office

No. 21, Sec. 1, Zhongshan Rd., Wuri Dist.,
Taichung City 414, Taiwan

TEL: +886 4 2338 2068

FAX: +886 4 2338 2161

E-mail : royal_sa@royal-spindles.com.tw

Jiji, Nantou

No. 66, Zhongji Rd., Jiji Township,
Nantou County 552, Taiwan

TEL: +886 4 2338 2068

FAX: +886 49 276 2812



www.royal-spindles.com